

TITLE: FSH Technical Service Guide
HA68A, HB68A, HC68A

DOC. NO.: FSH/TSG/001

PREPARED BY: LM

AUTHORIZED: JR

DISTRIBUTION: Tegningsarkiv, Svendborg (1)
DD (1)

ISSUE REVISION: 1.0
DATE: 2006-07-10

This document is the property of Contex A/S. The data contained herein, in whole or in part, may not be duplicated, used or disclosed outside the Recipient for any purpose other than to conduct technical evaluation. This restriction does not limit the Recipients right to use information contained in the data if it is obtained from another source without restriction.

 Document Revision Record				DRR
REV.	DATE	CHANGED BY	PAGES AFFECTED	BRIEF DESCRIPTION OF CHANGE
1.0	060710	LM	All	Original issue of document This document replaces FSH/TSM/001

Table of Contents

1.	Introduction.....	6
1.1	PRINTED CIRCUIT BOARD OVERVIEW	6
1.2	BLOCK DIAGRAM.....	6
2.	Electrical Tests and Adjustments	7
2.1	MARKING CODES FOR CIRCUIT BOARDS AND PROGRAMMED DEVICES	7
2.2	DOWNLOADING SCANNER FIRMWARE	7
2.2.1	<i>Erase and Restore Parameter Blocks.....</i>	8
2.3	SMPS TYPE 1 (HA68A AND HB68A)	9
2.3.1	<i>DC Voltages</i>	9
2.3.2	<i>Adjustments</i>	9
2.3.3	<i>Fuses</i>	9
2.4	SMPS TYPE 2 (HC68A)	10
2.4.1	<i>DC Voltages</i>	10
2.4.2	<i>Adjustments</i>	10
2.4.3	<i>Fuses</i>	10
2.5	LMF, LAMP AND MOTOR DRIVER BOARD	11
2.5.1	<i>DC Voltages</i>	11
2.5.2	<i>Lamp Driver.....</i>	11
2.5.3	<i>Stepper Motor Reference Voltages.....</i>	11
2.5.4	<i>Functional Test.....</i>	11
2.5.5	<i>Fuses</i>	11
2.5.6	<i>Markings</i>	11
2.5.7	<i>Jumper Settings</i>	12
2.5.8	<i>Hints.....</i>	12
2.6	CBK, CAMERA BOARD (HA68A, HB68A).....	14
2.6.1	<i>DC Voltages</i>	14
2.6.2	<i>Adjustments</i>	14
2.6.3	<i>Functional Test.....</i>	14
2.6.4	<i>Markings</i>	14
2.6.5	<i>Hints.....</i>	14
2.7	CBM, CAMERA BOARD (HC68A)	16
2.7.1	<i>DC Voltages</i>	16
2.7.2	<i>Adjustments</i>	16
2.7.3	<i>Functional Test.....</i>	16
2.7.4	<i>Markings</i>	16
2.7.5	<i>Hints.....</i>	16
2.8	SUC, SCANNER CONTROLLER BOARD (HA68A, HB68B).....	18
2.8.1	<i>DC Voltages</i>	18
2.8.2	<i>Functional Test.....</i>	18
2.8.3	<i>Markings</i>	18
2.8.4	<i>Switch Settings (Download Control Switches).....</i>	18
2.8.5	<i>Signal LEDs on the SUC-Board.....</i>	18
2.8.6	<i>Hints.....</i>	18
2.9	SUF, SCANNER CONTROLLER BOARD (HC68A)	20
2.9.1	<i>DC Voltages</i>	20
2.9.2	<i>Functional Test.....</i>	20
2.9.3	<i>Markings</i>	20
2.9.4	<i>Signal LEDs on the SUF Board</i>	20
2.9.5	<i>Hints.....</i>	20
2.10	IME, INTERFACE BOARD (HA68A, HB68A)	22
2.10.1	<i>DC Voltages</i>	22
2.10.2	<i>Functional Test.....</i>	22
2.10.3	<i>Markings</i>	22
2.11	IMG, INTERFACE BOARD (HC68A).....	23
2.11.1	<i>DC Voltages</i>	23
2.11.2	<i>Functional Test.....</i>	23
2.11.3	<i>Markings</i>	23

2.12	SKD, OPERATOR PANEL.....	24
2.12.1	DC Voltages	24
2.12.2	Functional Test.....	24
2.12.3	Markings	24
2.12.4	Switch Setting (Scanner ID).....	24
2.13	CRB, SMART CARD READER	26
2.13.1	DC Voltages	26
2.13.2	Functional Test.....	26
2.13.3	Markings	26
2.13.4	DIP Switch Setting	26
2.13.5	Signal LED on the CRB Board.....	26
2.14	PAPER SENSORS	28
2.15	CHECK AND ADJUSTMENT OF EXTENDED THICKNESS SENSOR	28
3.	CCD Camera.....	30
3.1	DESCRIPTION OF CCD CAMERA	30
3.2	CCD CAMERA CHECK AND ADJUSTMENT	34
3.2.1	Check of Light Profiles.....	34
3.2.2	Check and Adjustment of Focus.....	36
3.2.3	Check and Adjustment of Scan-Width	38
3.2.4	Check and Adjustment of CCD-Centering	40
3.2.5	Check and Adjustment of Vertical Positioning.....	41
3.2.6	Final Check.....	42
4.	General Maintenance	46
4.1	STEP BY STEP PROCEDURE FOR GENERAL MAINTENANCE.....	46
4.1.1	Clean the Scanning Area.....	46
4.1.2	Check CCD Camera Adjustment.....	46
4.1.3	Run Scanner Maintenance.	46
5.	Troubleshooting	48
5.1	POWER-ON SELF-TEST	48
5.2	LED INDICATORS ON OPERATOR PANEL	49
5.3	ERROR CODES.....	50
5.3.1	Error Codes displayed on the Operator Panel	50
5.3.2	Error Codes displayed on the PC Screen.....	50
5.4	TROUBLESHOOTING HINTS	51
6.	Disassembly and Assembly.....	54
6.1	LID COVER	54
6.2	TOP COVER.....	54
6.3	ELECTRONICS BOX	55
6.4	SCANNER CHASSIS.....	55
6.5	MIRROR CHASSIS.....	55
7.	Replacement of Parts.....	58
7.1	SUX- BOARD AND IMX-BOARD.....	58
7.2	LMF-BOARD, SMPS (PSU), RFI FILTER, AND FAN	58
7.3	CBX-BOARD.....	59
7.4	STEPPER MOTOR.....	59
7.5	PAPER ENTRY SENSOR.....	60
7.6	PAPER EXIT SENSOR	60
7.7	IDLER ROLLERS	60
7.8	DRIVE ROLLERS.....	61
7.9	LAMP CARTRIDGE, LCAA	62
8.	SCANtest	70
8.1	DESCRIPTION OF SCANTEST	71
8.1.1	Test 1, Scanner Information	71
8.1.2	Test 2, LED Test.....	71
8.1.3	Test 3, Key Test	71
8.1.4	Test 4, Original-Sensor Test.....	71
8.1.5	Test 5, Lamp Test	72
8.1.6	Test 6, Motor Test	72
8.1.7	Test 7, Complete Hardware Test.....	72

8.1.8	Test 9, Camera Adjustment	72
8.1.9	Test 12, Adjustment of Y-Axis Scaling.....	72
8.1.10	Test 13, Switch Scanner to Test Mode.....	72
8.1.11	Test 20, Noise Test	73
8.1.12	Test 21, SCANDump	73
9.	Wiring Diagram	75
10.	Special Service Tools.....	77
11.	Appendix A, Error Codes	78

List of Figures

Fig. 1-1,	Hx68A Block Diagram.....	6
Fig. 2-1,	SMPS Type 1 Test Points.....	9
Fig. 2-2,	SMPS Type 2 Test Points.....	10
Fig. 2-3,	LMF Component Layout.....	13
Fig. 2-4,	CBK Component Layout.....	15
Fig. 2-5,	CBM Component Layout	17
Fig. 2-6,	SUC Component Layout	19
Fig. 2-7,	SUF Component Layout.....	21
Fig. 2-8,	IME Component Layout.....	22
Fig. 2-9,	IMG Component Layout	23
Fig. 2-10,	SKDH Component Layout	25
Fig. 2-11,	CRB Component Layout.....	27
Fig. 2-12,	Adjustment of Extended Thickness Sensor	29
Fig. 3-1,	CCD Camera	32
Fig. 3-2,	Relations between Optical Adjustment Pattern and Screen Images.....	33
Fig. 3-3,	Hx68A Uncorrected Light Profiles	35
Fig. 3-4,	Hx68A Corrected Light Profiles	35
Fig. 3-5,	Hx68A Focus Signals.....	37
Fig. 3-6,	Hx68A Scan-Width.....	39
Fig. 3-7,	Hx68A CCD-Centering and Vertical Positioning	42
Fig. 3-8,	CCD Camera Overview (Adjustments).....	43
Fig. 3-9,	Optical Adjustment Pattern, 36"	44
Fig. 3-10,	Focus Pattern, 40"	45
Fig. 4-1,	SM Calibration Sheet, 42".....	47
Fig. 6-1,	Lid Cover	56
Fig. 6-2,	Disassembly	57
Fig. 7-1,	Cable Routing.....	63
Fig. 7-2,	Inside Electronics Box	64
Fig. 7-3,	Stepper Motor.....	65
Fig. 7-4,	Drive-Belt Tightener Adjustment.....	66
Fig. 7-5,	Paper Sensors	67
Fig. 7-6,	Drive System	68
Fig. 7-7,	Scanner Cross Section	69
Fig. 8-1,	Noise Test, Example.....	74
Fig. 9-1,	Hx68A Wiring Diagram.....	76

1. Introduction

The purpose of this Technical Service Guide is to supply the information necessary to service the following scanner models

HA68A, HB68A, HC68A

Note: Throughout this TSG the abbreviation Hx68A will be used when referring to all of the above listed scanner models

1.1 Printed Circuit Board Overview

The table below gives an overview of the printed circuit boards used in the different models.

Printed Circuit Board	Reference	HC68A	HB68A	HA68A
Switch Mode Power Supply Type 1	Section 2.3		x	x
Switch Mode Power Supply Type 2	Section 2.4	x		
LMF, Lamp and Motor Driver Board	Section 2.5	x	x	x
CBK, Camera Board	Section 2.6		x	x
CBM, Camera Board	Section 2.7	x		
SUC, Controller Board	Section 2.8		x	x
SUF, Controller Board	Section 2.9	x		
IME, Interface Module, IEEE 1394 and USB2.0	Section 2.10		x	x
IMG, Interface Module, IEEE 1394 and USB2.0	Section 2.11	x		
SKD, Operator Panel	Section 2.12	x	x	x
CRB, Smart Card Reader	Section 2.13	x	x	x

1.2 Block Diagram

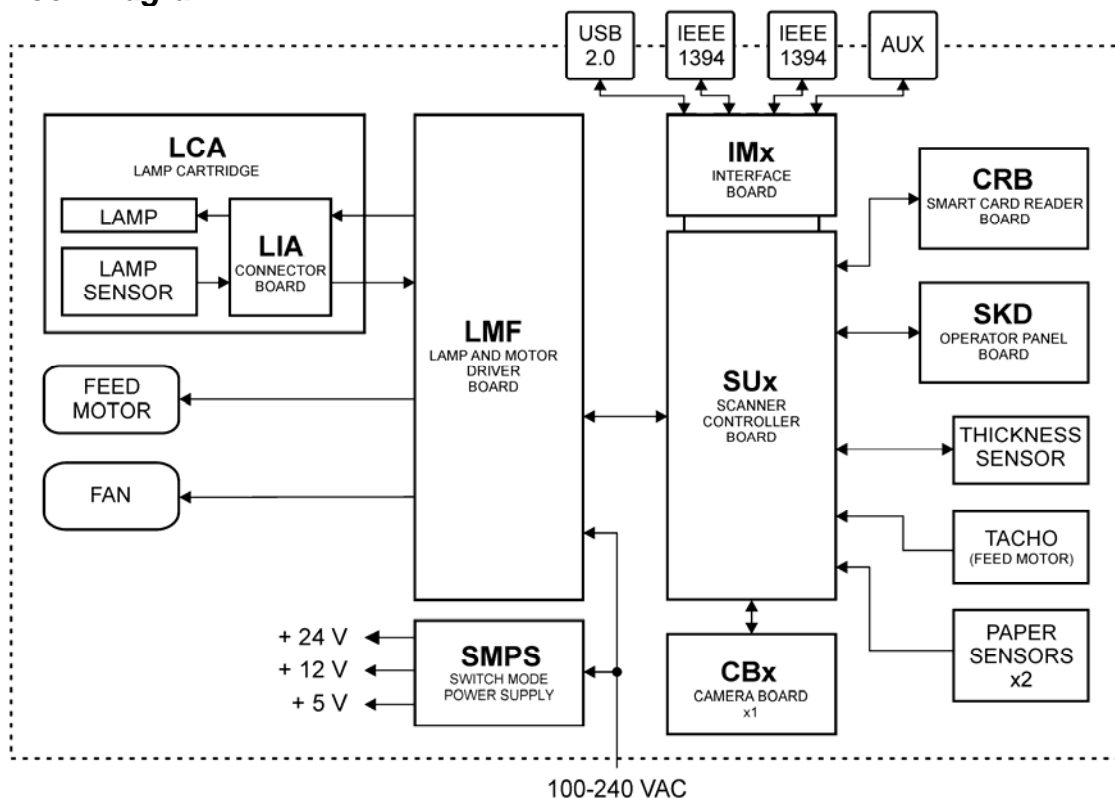

Fig. 1-1, Hx68A Block Diagram

2. Electrical Tests and Adjustments

Required Test Equipment:

Multimeter, $R_i > 10$ Mohm.

PC with the following installed:

- SCANtest
- Scanner Maintenance
- USB and/or IEEE 1394 interface
- Scanner Maintenance

SCANtest is described in Chapter 8, page 70.

Scanner Maintenance is described in Section 4.1.3, page 46.

2.1 Marking Codes for Circuit Boards and Programmed Devices

All circuit boards are identified by a 4-letter code, where the *fourth* letter designates a specific variant of the board. The board identification code is followed by a board revision number (functional level) and for newer boards also an extra letter in parenthesis. This extra letter is unimportant in this connection.

The marking of all printed circuit boards may be exemplified by the marking of the SUF Board:

SUFA02(B)

which designates SUF Board, variant **A**, revision **02**. The (B) is of no importance and should be neglected.

The *revision number* is updated only if the functionality of the board has been changed. Updated boards will always be backwards compatible.

2.2 Downloading Scanner Firmware

The scanner firmware is stored in Flash Memory on the SUx Board.

Firmware is downloaded to the scanner through the IEEE 1394 or USB2.0 interface. Please refer to any *readme.txt* on the firmware disk for download instructions.

The download program is started by double-clicking the self extracting *firmware* file.

It is recommended to disable WIDESystem before upgrading the firmware to prevent any possible problems caused by this program accessing the scanner during the upgrade.

Scanner firmware is available on the support home page.

If the scanner does not go into Boot Mode when the download program is started, the scanner can be forced into Boot Mode by turning it OFF, setting SW7 on the CRB board switch to ON (see page 27), and turn the scanner back ON. The scanner will now be in Boot Mode and new firmware can be downloaded as described above. When the new firmware has been successfully downloaded, turn the scanner OFF, set SW7 back to OFF, and turn the scanner ON for normal operation.

2.2.1 Erase and Restore Parameter Blocks

When trouble shooting it may be advisable to clear the parameter blocks in the scanner to reset these to default values.

The parameter blocks can be erased from Scanner Maintenance by right-click on the Title Bar and select Erase Parameter Blocks from the pull-down menu.

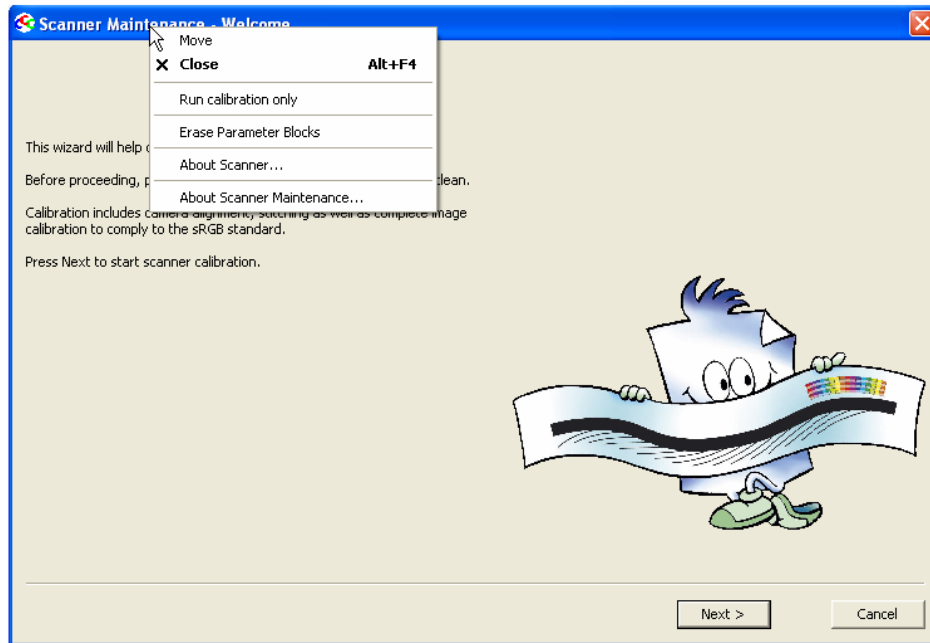

Note: Always run Scanner Maintenance after Erasing Parameter Blocks.

2.3 SMPS Type 1 (HA68A and HB68A)

This SMPS is used in HA68A and HB68A

All test points referred to below are shown in Fig. 2-1 page 9.

All DC voltages are measured relative to CON2, pin 4,5,8 (GND).



The connector CON1 is connected directly to the line voltage and constitute a risk of electric shock, or injury to persons

2.3.1 DC Voltages

Ref. on Fig. 2-1	DC Voltage
CON2, pin1	+12 V +1/-0 V
CON2, pin2,3	+5.3 V +0/-0.1 V
CON2, pin4,5,8	GND
CON2, pin6	N.C.
CON2, pin7	+24 V ± 2 V

2.3.2 Adjustments

IMPORTANT: The output voltages of the SMPS are all factory set and should normally not be adjusted.

The (5V) output voltage should be no more than 5.3 V measured between GND and CON2, pin 2,3 on the SMPS, and no less than 5.1 V measured between GND and D3, bottom on the CBx-Board.

If the voltage is not within these limits, it may be adjusted by potentiometer VR1 on the SMPS, see

Fig. 2-1, page 9.

2.3.3 Fuses

No service replaceable fuses

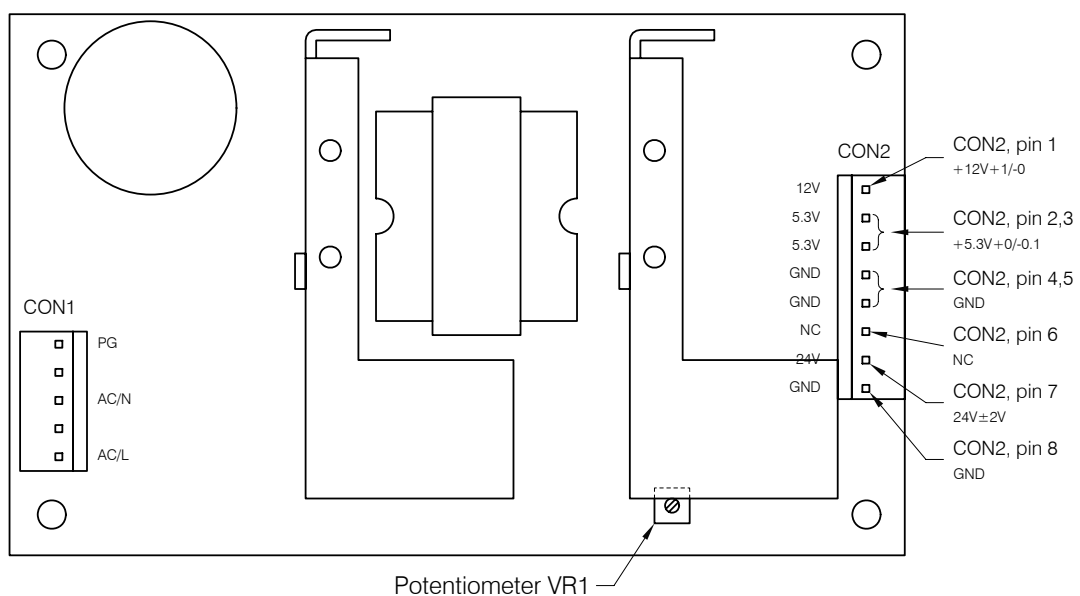



Fig. 2-1, SMPS Type 1 Test Points

2.4 SMPS Type 2 (HC68A)

This SMPS is used in HC68A

All test points referred to below are shown in Fig. 2-2 page 10.

All DC voltages are measured relative to TB2, pin 1,2 (GND).



The connector CON1 is connected directly to the line voltage and constitute a risk of electric shock, or injury to persons

2.4.1 DC Voltages

Ref. on Fig. 2-2	DC Voltage
TB2, pin 1,2	+5.3 V +0/-0.1 V
TB2, pin 3,4,5,6	GND
TB2, pin 7	+12.5 V \pm 0.5 V
TB2, pin 8	+24 V \pm 1 V

2.4.2 Adjustments

IMPORTANT: The output voltages of the SMPS are all factory set and should normally not be adjusted.

The 5.3V output voltage should be no more than 5.3 V measured between GND and TB2, pin 1,2 (5.3V) on the SMPS, and no less than 5.1 V measured between GND and D3, bottom on the CBK board. If the voltage is not within these limits, it may be adjusted by potentiometer VR1 on the SMPS.

2.4.3 Fuses

No service replaceable fuses

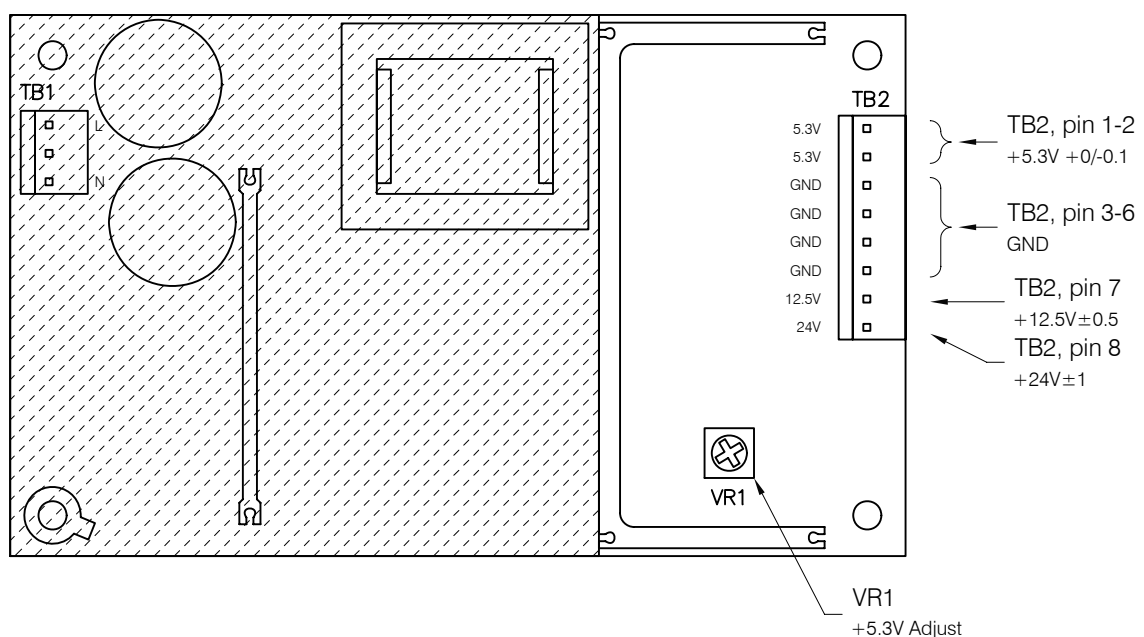

Fig. 2-2, SMPS Type 2 Test Points

2.5 LMF, Lamp and Motor Driver Board

All test points referred to below are shown in Fig. 2-3, page 13.

All DC voltages are measured relative to test points, TP4, 12, 13, 17 (GND).

CAUTION:

Connectors J1, J7 and all the components in the hatched area are connected to the line voltage and constitute a risk of electric shock, or injury to persons.

2.5.1 DC Voltages

Ref. on Fig. 2-3	DC Voltage
Test point 4, 12, 13, 17	GND
TP8 - GND	+3.3 V \pm 0.1 V
TP9 - GND	+5.3 V \pm 0.2 V
TP10 - GND	+12.0 V \pm 1.0 V
TP18 - GND	+24.0 V \pm 2 V
TP16 - GND	+5.0 V \pm 0.15 V
TP15 - GND	+12.0 V \pm 0.3 V
TP5 - TP7 *	+200 V \pm 20 V
TP7 - TP6*	-200 V \pm 20 V

* Caution: These test points are at high voltage level and constitute a risk of electric shock, or injury to persons.

2.5.2 Lamp Driver

The LMF board is designed to work with a calibrated Lamp Cartridge, which means that there is no adjustment of the lamp driver.

2.5.3 Stepper Motor Reference Voltages

No adjustment of Stepper Motor Reference Voltage on LMF-Board.

2.5.4 Functional Test

SCANtest: Test 5, Lamp Test
Test 6, Motor Test

2.5.5 Fuses

The type and rating of the fuse on the LMFA-Board is:

F1: T2.0AH/250V, type IEC 127- 2/5, UL R/C



IMPORTANT: For continued protection against risk of fire, replace only with same type and rating of fuse.

2.5.6 Markings

HA68A	LMFAdd
HB68A	LMFAdd
HC68A	LMFAdd
where dd = board revision number	

2.5.7 Jumper Settings

Jumper:	JP1
	not installed

2.5.8 Hints

Jumper on JP1: Not installed: Lamp controlled by SUx
 Installed: Lamp constant ON

Control signals on J11:

pin 2: Lamp ON/OFF, LOW = ON
pin 8: Feed-Motor Step Pulse
pin 11: Feed-Motor Direction, LOW = FORWARD

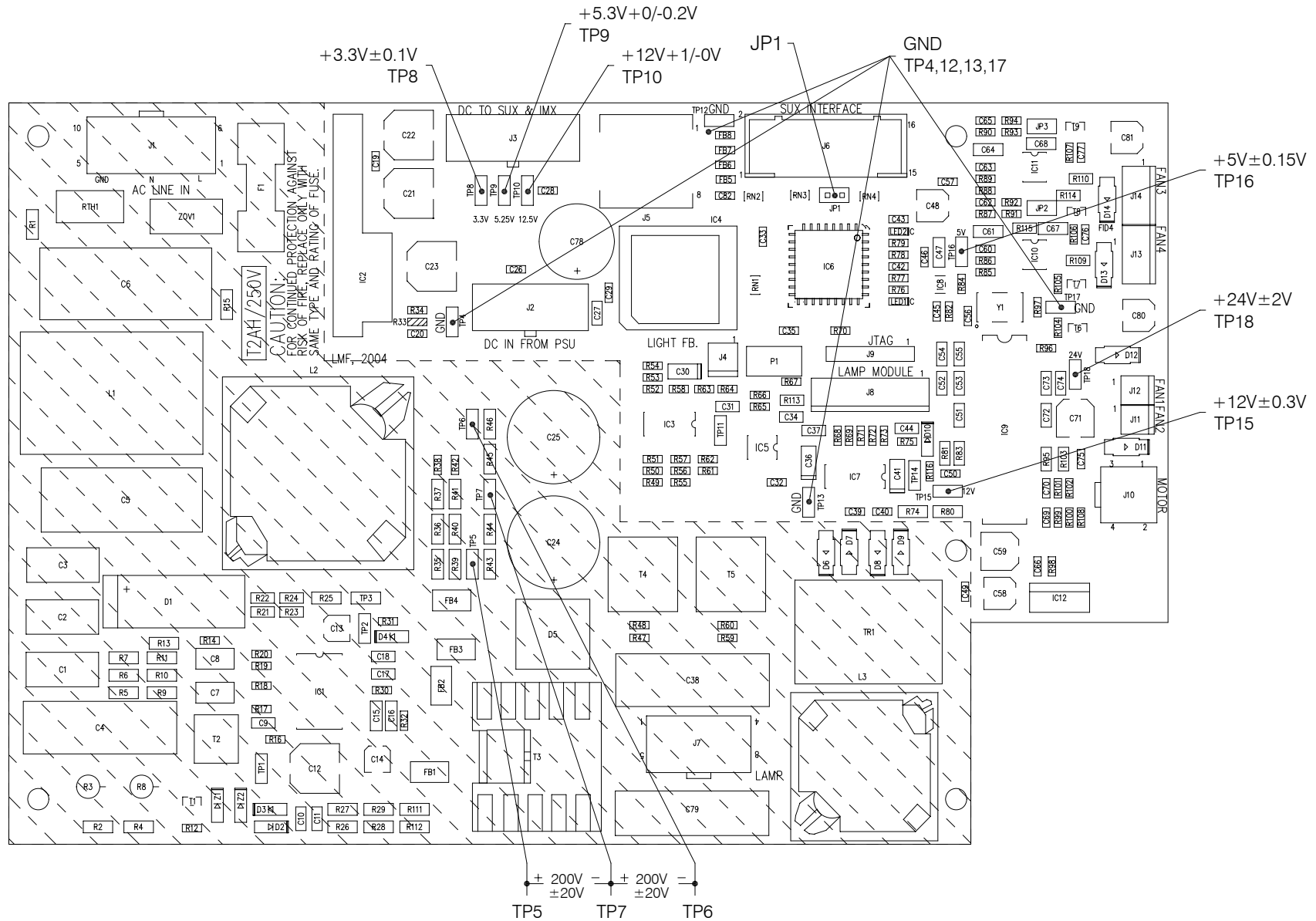

Fig. 2-3, LMF Component Layout

2.6 CBK, Camera Board (HA68A, HB68A)

This board is used in HA68A and HB68A.

All test points referred to are shown in Fig. 2-4, page 15.

All voltages are measured relative to test point J701, pin3,4 (GND).

Note: The test points are covered by the EMC Cage, and are not accessible when the CKB is mounted on the camera.

2.6.1 DC Voltages

Ref. on Fig. 2-4	DC Voltage	Remarks
J701, pin3,4	GND	GND reference
D3, bottom	+5.3 V +0/-0.2 V	From SU _x /SMPS
D3, top	+5.0 V ± 0.15 V	Derived from +5.3V
D2, top	+5.0 V ± 0.15 V	Derived from +5.3V
D4, bottom	+12.0 V +1/-0 V	From SU _x /SMPS, used for CCD
D4, top	+11.6 V ± 0.6 V	Derived from +12V
C301, bottom	+3.3 V ± 0.1 V	From SU _x / LMF
D308, bottom	+1.8 V ± 0.1 V	Derived from +3.3V

2.6.2 Adjustments

The gain and offset of the CBK-Board are adjusted automatically by running Scanner Maintenance.

2.6.3 Functional Test

SCANtest: Test 7, Complete Hardware Test.
Test 9, Camera Adjustment.

2.6.4 Markings

HA68A	CBKBdd
HB68A	CBKBdd
where dd = board revision number	

2.6.5 Hints

+3.3 V is supplied from the LMF via the SU_x-Board.

+5.3 V and +12 V are supplied from the SMPS via the SU_x-Board.

CCD: The lines of pixels on the CCD are arranged as follows:

Upper line on the CCD	Red
2nd line on the CCD	Green
3rd line on the CCD	Blue
Lower line on the CCD	B/W

As the image is mirrored an even number of times (mirror chassis and lens), the Red line remains upper line when referred to the original.

After replacement of CBK-Board, do:

- CCD-Centering, Section 3.2.4, page 40.
- Vertical Positioning, Section 3.2.5, page 41.
- Check Scan-Width. If it is within the limits given in Section 3.2.3, page 38, Focus will also be OK, and no further adjustments are required.
- Run Scanner Maintenance, Section 4.1.3, page 46.

These adjustments can be made without loosening the Camera Fixing Screws and without loosening the Focus Lock Screw.

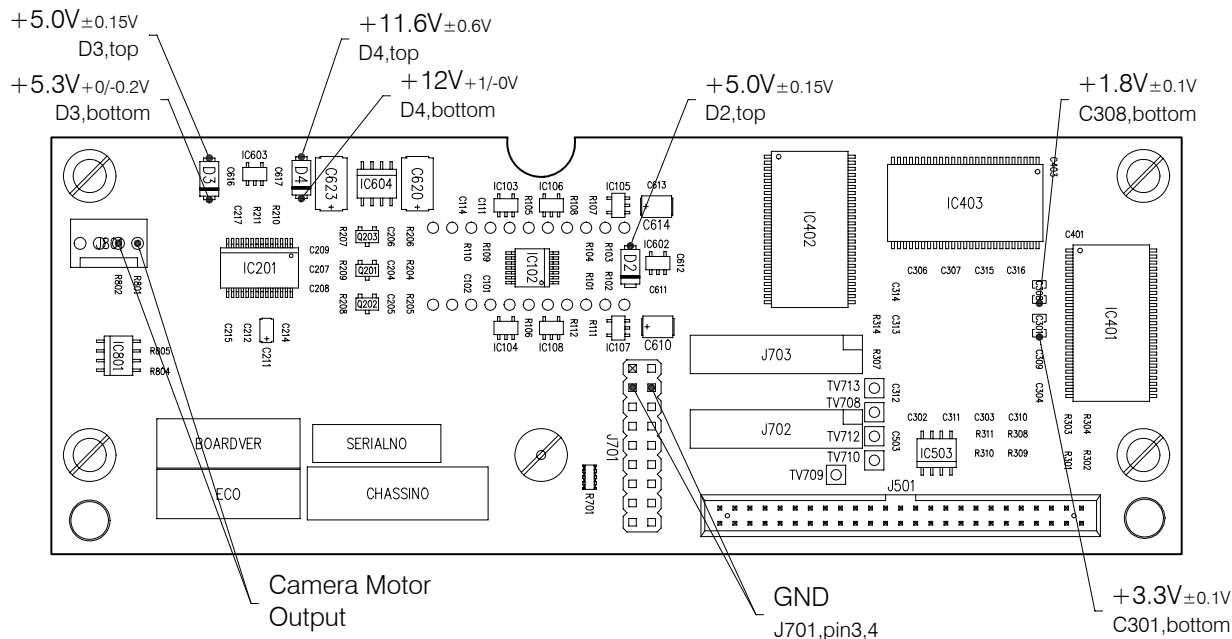

Fig. 2-4, CBK Component Layout

2.7 CBM, Camera Board (HC68A)

This board is used in HC68A.

All test points referred to are shown in Fig. 2-4, page 15.

All voltages are measured relative to test point GND.

Note: The test points are covered by the EMC Cage, and are not accessible when the CKB is mounted on the camera.

2.7.1 DC Voltages

Ref. on Fig. 2-4	DC Voltage	Remarks
J701, pin3,4	GND	GND reference
D3, bottom	+5.3 V +0/-0.2 V	From SUx/SMPS
D3, top	+5.0 V \pm 0.2 V	Derived from +5.3V
D2, top	+5.0 V \pm 0.2 V	Derived from +5.3V
D4, bottom	+12.0 V +1/-0 V	From SUx/SMPS, used for CCD
D4, top	+11.6 V \pm 0.6 V	Derived from +12V
C301, bottom	+3.3 V \pm 0.1 V	From SUF / LMF
D308, bottom	+1.8 V \pm 0.1 V	Derived from +3.3V

2.7.2 Adjustments

The gain and offset of the CBM board are adjusted automatically by running Scanner Maintenance.

2.7.3 Functional Test

SCANtest: Test 7, Complete Hardware Test
Test 9, Camera Adjustment.

2.7.4 Markings

HC68A	CBMAdd
where dd = board revision number	

2.7.5 Hints

+3.3 V is supplied from the LMF via the SUx Board.

+5.3 V and +12 V are supplied from the SMPS via the SUx Board.

CCD: The lines of pixels on the CCD are arranged as follows:

Upper line on the CCD	Red
2nd line on the CCD	Green
3rd line on the CCD	Blue
Lower line on the CCD	B/W

As the image is mirrored an even number of times (mirror chassis and lens), the Red line remains upper line when referred to the original.

After replacement of CBM Board, do:

- CCD-Centering, Section 3.2.4, page 40.
- Vertical Positioning, Section 3.2.5, page 41.
- Check Scan-Width. If it is within the limits given in Section 3.2.3, page 38, Focus will also be OK, and no further adjustments are required.
- Run Scanner Maintenance, Section 4.1.3, page 46.

These adjustments can be made without loosening the Camera Fixing Screws and without loosening the Focus Lock Ring / Lock Screw.

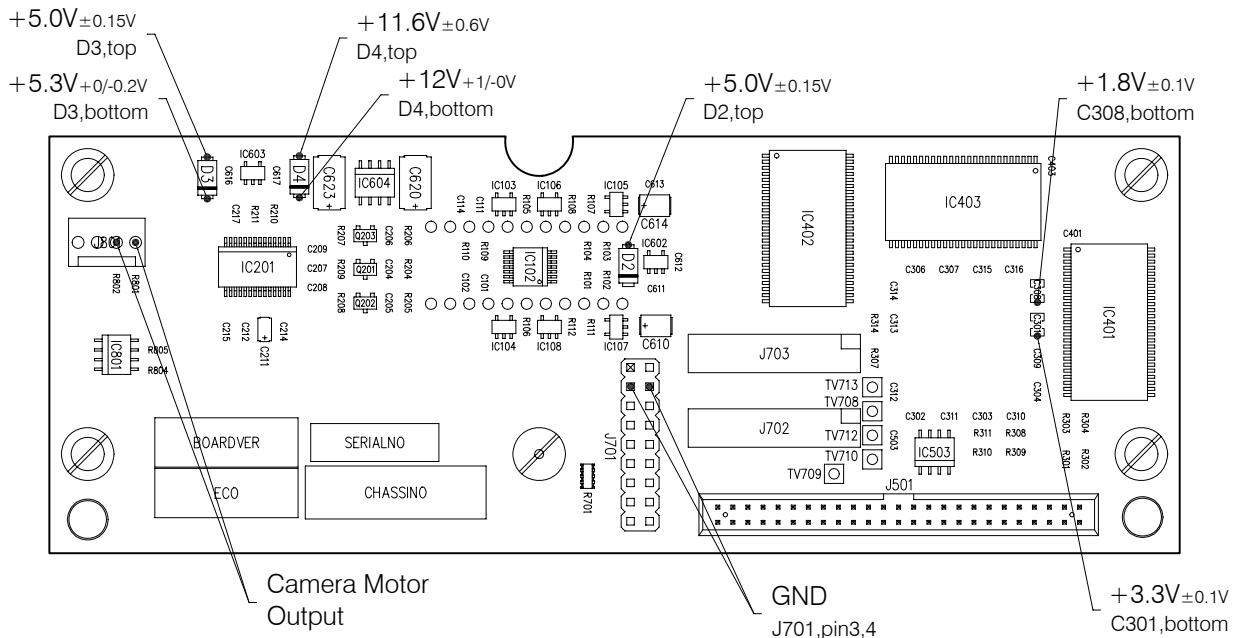

Fig. 2-5, CBM Component Layout

2.8 SUC, Scanner Controller Board (HA68A, HB68B)

This board is used in HA68A and HB68A.

All test points referred to below are shown in Fig. 2-6, page 19.

All voltages are measured relative to test point GND2.

2.8.1 DC Voltages

Ref. on Fig. 2-6	DC Voltage	Remarks
GND2	GND	GND reference
12V_CAM	+12 V + 1/-0V	Supply for Camera Board
5V_CAM	+5.3 V +0/-0.2 V	Supply for Camera Board
+3	+3.3 V \pm 0.1 V	Supplied from LMF
+5V	+5.1 V +0.1/-0.2 V	Derived from 5.3V on SUC
APEX_SUP	+1.8 V \pm 0.1 V	Derived from 3.3V on SUC
APEX_PLL	+1.8 V \pm 0.05 V	Derived from 3.3V on SUC

2.8.2 Functional Test

SCANtest: Test 1 Scanner Information
Test 7, Complete Hardware Test

2.8.3 Markings

HA68A	SUCLdd
HB68A	SUCNdd
where dd = board revision number	

2.8.4 Switch Settings (Download Control Switches)

The download program reads the Download Control Switches, SW1 and SW2, on the SUC-Board to check if the actual firmware and the SUC hardware are compatible.

The Download Control Switches are factory set, and the setting must not be changed.

2.8.5 Signal LEDs on the SUC-Board

The three signal LEDs on the SUC-Board are for debugging purposes only. The ON/OFF pattern displayed by these LEDs is not intended for general troubleshooting.

2.8.6 Hints

After replacement of SUC-Board:

As all scanner parameters are stored in the Flash Memory on the SUC-Board, the following steps should be carried out after replacement of the SUC-Board:

- Download Firmware
- Enter Serial Number of scanner into Flash Memory (SCANtest, Test 1). The serial number of the scanner is found on the marking label on back of the scanner
- Run Scanner Maintenance

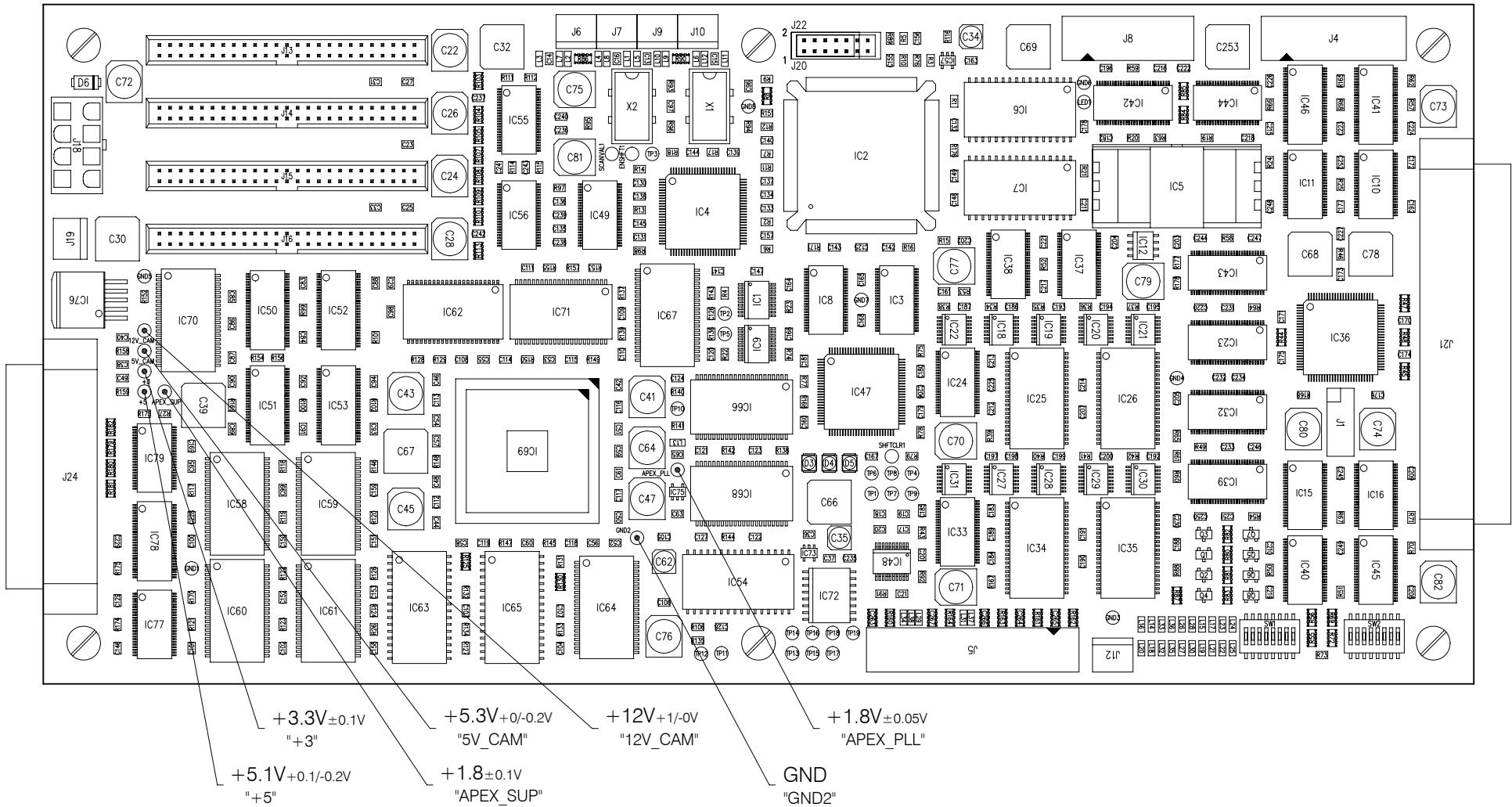

Fig. 2-6, SUC Component Layout

2.9 *SUF*, Scanner Controller Board (HC68A)

This board is used in HC68A.

All test points referred to below are shown in Fig. 2-7, page 21.

All voltages are measured relative to test point GND2.

2.9.1 DC Voltages

Ref. on Fig. 2-7	DC Voltage	Remarks
GND2	GND	GND reference
12V_CAM	+12 V + 1/-0V	Supply for Camera Board, Elevation Motor (ATAC)
5V_CAM	+5.3 V +0/-0.2 V	Supply for Camera Board, MDA Board (ATAC)
+3	+3.3 V \pm 0.1 V	
+5V	+5.1 V +0.1/-0.2 V	Derived from 5.3V on <i>SUF</i>
APEX_SUP	+1.8 V \pm 0.1 V	
APEX_PLL	+1.8 V \pm 0.05 V	

2.9.2 Functional Test

SCANtest: Test 1 Scanner Information
Test 7, Complete Hardware Test

2.9.3 Markings

HC68A	SUFBdd
where dd = board revision number	

2.9.4 Signal LEDs on the *SUF* Board

The three signal LEDs on the *SUF* board are for debugging purposes only. The ON/OFF pattern displayed by these LEDs is not intended for general troubleshooting.

2.9.5 Hints

*After replacement of *SUF* board:*

As all scanner parameters are stored in the Flash Memory on the *SUF* board, the following steps should be carried out after replacement of the *SUF* board:

- Download Firmware
- Run Scanner Maintenance
- Enter Serial Number of scanner into Flash Memory (SCANtest, Test 1). The serial number of the scanner is found on the marking label on back of the scanner

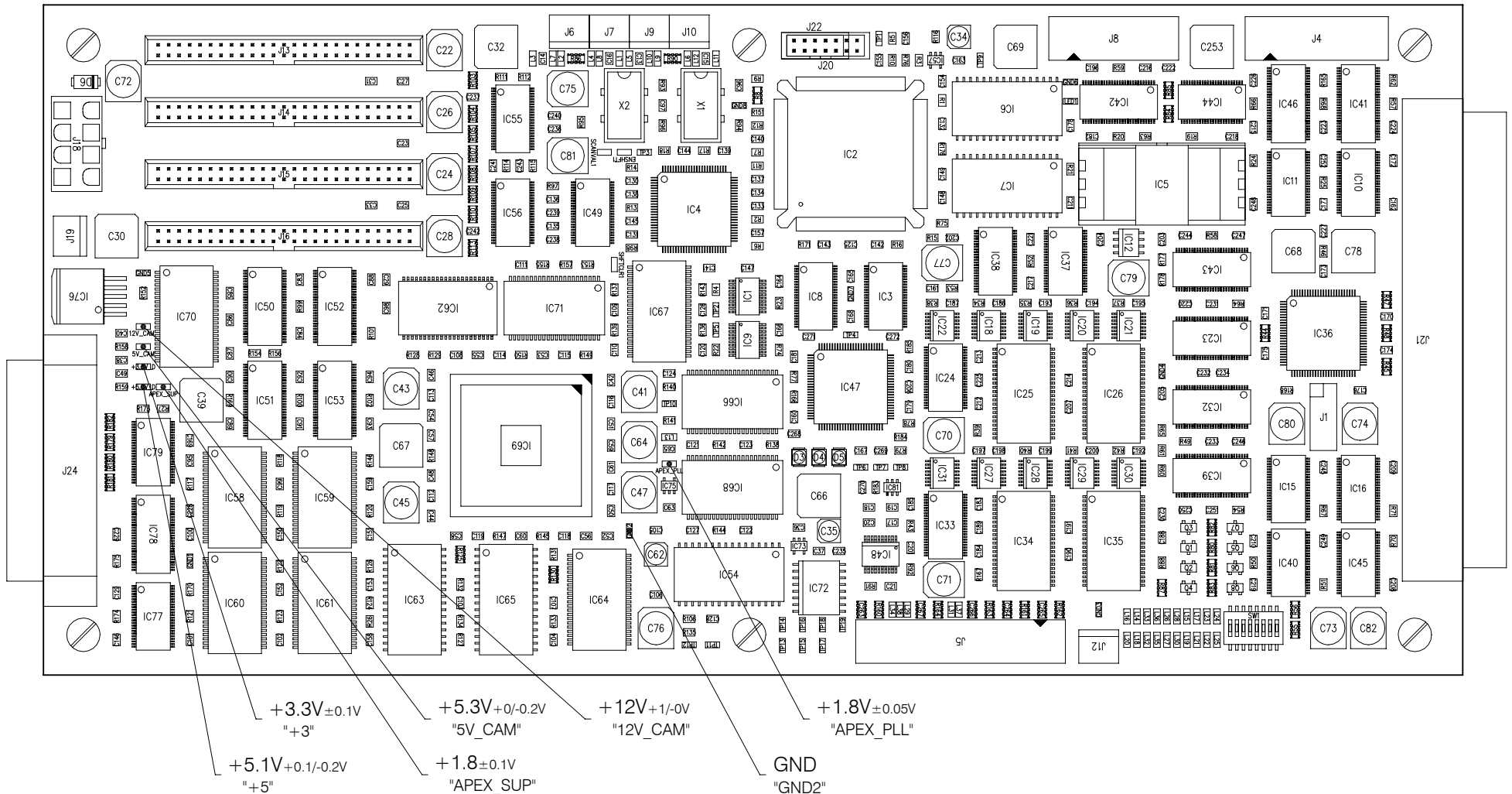

Fig. 2-7, SUF Component Layout

2.10 IME, Interface Board (HA68A, HB68A)

This board is used in HA68A and HB68A.

All test points referred to below are shown in Fig. 2-8 page 22.

All voltages are measured relative to test points GND_T1.

2.10.1 DC Voltages

Ref. on Fig. 2-8	DC Voltage
GND_T1	GND
R34, top	+5.3 V +0/-0.2 V
+5V0_D1	+5.2 V +0/-0.2 V
+3V3_D1	+3.3 V ± 0.1 V

2.10.2 Functional Test

Connect the computer to each separate port in turn and start SCANTest or WIDESystem to check if the scanner connects with all ports available.

2.10.3 Markings

HA68A	IMEAdd
HB68A	IMEAdd
where dd = board revision number	

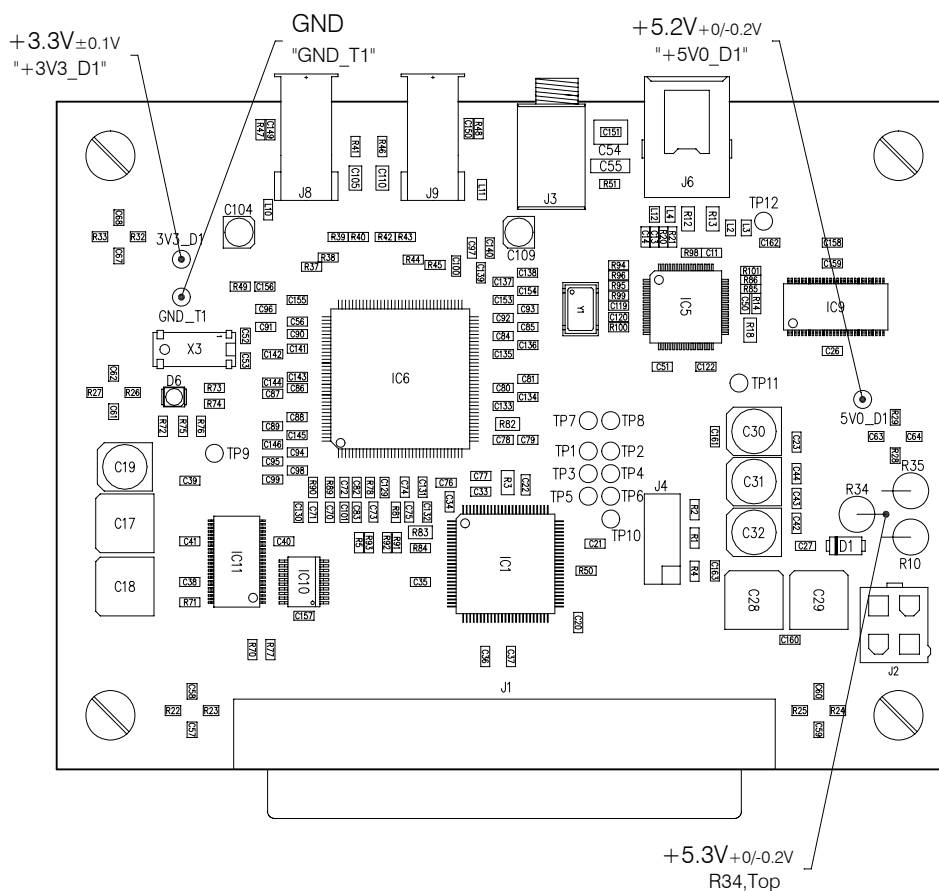

Fig. 2-8, IME Component Layout

2.11 IMG, Interface Board (HC68A)

This board is used in HC68A.

All test points referred to below are shown in Fig. 2-9 page 23.

All voltages are measured relative to test points GND_T1.

2.11.1 DC Voltages

Ref. on Fig. 2-10	DC Voltage
GND_T1	GND
R34, top	+5.3 V +0/-0.2 V
+5V0_D1	+5.2 V +0/-0.2 V
+3V3_D1	+3.3 V ± 0.1 V

2.11.2 Functional Test

Connect the computer to each separate port in turn and start SCANtest or WIDESystem to check if the scanner connects with all ports available.

2.11.3 Markings

HC68A	IMGAdd
where dd = board revision number	

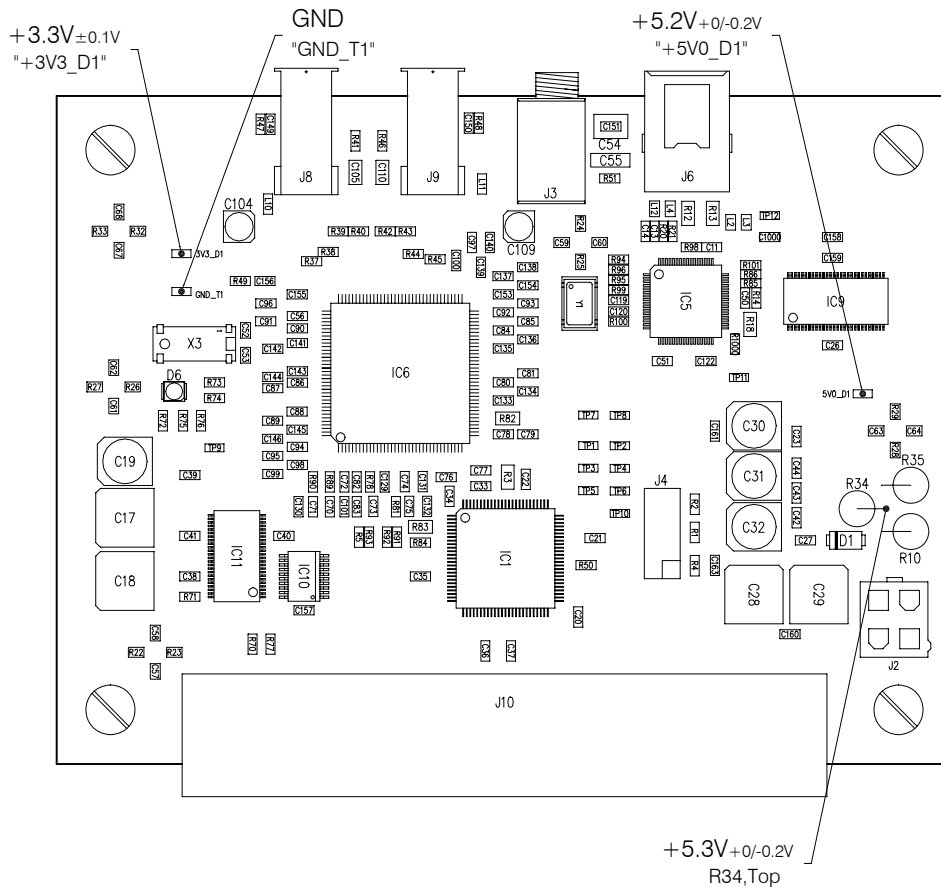

Fig. 2-9, IMG Component Layout

2.12 SKD, Operator Panel

All test points referred to are shown in Fig. 2-10, page 25.
All voltages are measured relative to PCB Ground Plane.

2.12.1 DC Voltages

Ref. on Fig. 2-10	DC Voltage
J2, pin 3	+3.3 V \pm 0.1 V
C1, top	+5.1 V +0.1/-0.2 V

2.12.2 Functional Test

SCANtest: Test 1, Scanner ID Switch
Test 2, LED test
Test 3, Key test

2.12.3 Markings

HA68A	SKDHdd
HB68A	SKDHdd
HC68A	SKDHdd
where dd = board revision number	

2.12.4 Switch Setting (Scanner ID)

DIP Switch Setting:

	SW1	SW2	SW3	SW4	SW5	SW6	SW7	SW8	HEX
HA68A	OFF	OFF	ON	OFF	ON	ON	ON	OFF	0x2E
HB68A	OFF	OFF	ON	ON	OFF	ON	ON	OFF	0x36
HC68A	OFF	OFF	ON	ON	OFF	ON	ON	OFF	0x36

An undefined switch setting may cause the 'Invalid Scanner ID' Error Code to be displayed on the Operator Panel.

CAUTION:

The Scanner ID Switch setting is stored in the Flash Memory on the SUx-Board. Every time the scanner is switched ON, it reads the switch setting and if it is different from the stored value, the new setting will be stored and all other stored scanner parameters (including Stitching, Basic Calibration and Color Calibration) will be cleared to default values.

This means that the scanner must be calibrated using Scanner Maintenance afterwards to restore the actual values.

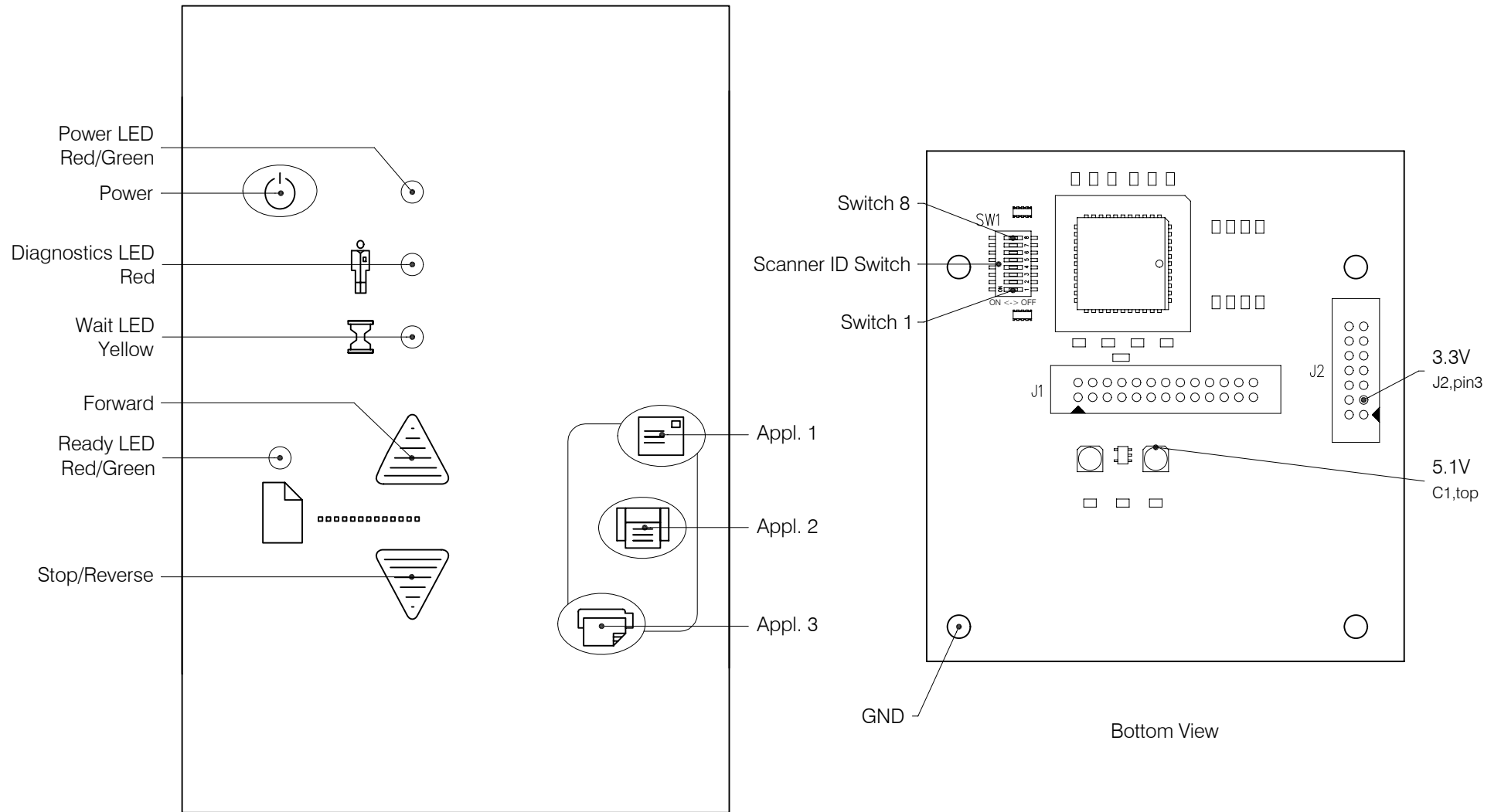

Fig. 2-10, SKDH Component Layout

2.13 CRB, Smart Card Reader

All test points referred to below are shown in Fig. 2-11, page 27.

All DC voltages are measured relative to test point J4, pin10 (GND).

2.13.1 DC Voltages

NOTE: Does not apply to CRBC

Ref. on Fig. 2-11	DC Voltage	Remarks
J4, pin10	GND	GND reference
VR1, pin3	+5.3 V +0/-0.2 V	From SUx / LMF
VR1, tap	+3.3 V ±0.1V	Derived from +5.3V

2.13.2 Functional Test

SCANtest: Test 1, Scanner Model (Smart Card)

2.13.3 Markings

HA68A	CRBAdd
HB68A	CRBAdd
HC68A	CRBCdd
where dd = board revision number	

2.13.4 DIP Switch Setting

The DIP Switch may be accessed through the slot in the right hand side of the Top Cover, see Fig. 2-11, page 27.

SCSI related switch settings (SW No. 1, 2, 3, 4, and 5) do not apply to the Hx68A scanners, but should be set to the default settings shown in the table below.

Default DIP Switch Setting:

Switch No:	1	2	3	4	5	6	7	8
	ON	OFF	ON	ON	OFF	OFF	OFF	OFF

Troubleshooting and Test Switches:

Function	Switch No:	1	2	3	4	5	6	7	8
<i>Boot start-up</i>	Forced:	ON	OFF	ON	ON	OFF	OFF	ON	
	Normal:							OFF	
<i>Factory testing</i>	Self-test:	ON	OFF	ON	ON	OFF	OFF		ON
	Normal:								OFF

SW1-6 Do not apply to Hx68A, set to default.

SW7: If download fails, try to set SW7 to ON. For normal operation SW7 must be set to OFF.

SW8: Reserved for factory testing and must be set to OFF.

NB! The switches are read at power-on only, and the scanner must be switched OFF and back ON for a changed switch setting to become effective.

2.13.5 Signal LED on the CRB Board

The signal LED (LED1) on the CRB Board turns ON when a Smart Card is inserted. It only signals, that a Smart Card has been inserted, it does not show whether the card is valid or not.

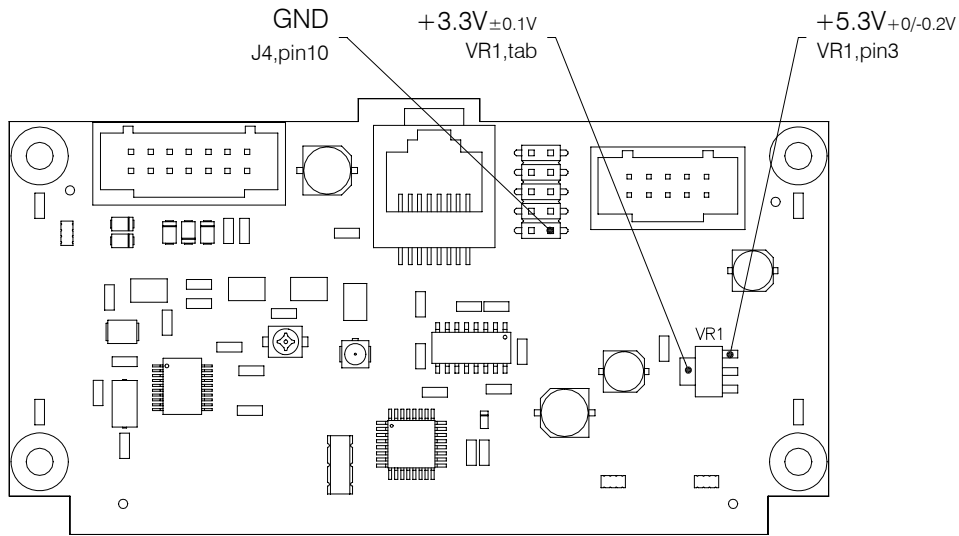

Above picture only refers to CRBA

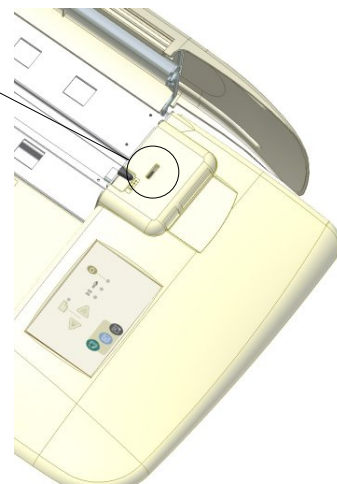
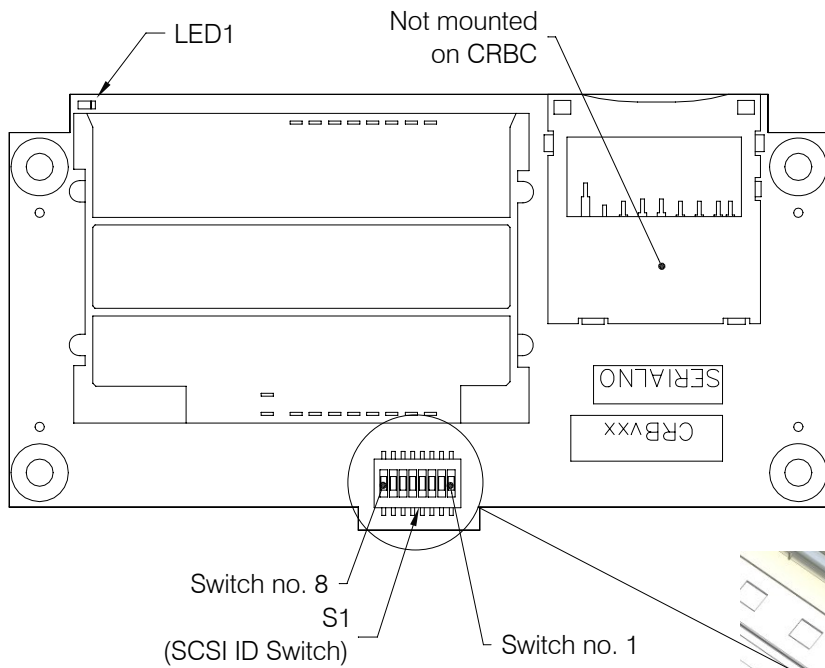

Fig. 2-11, CRB Component Layout

2.14 Paper Sensors

See Fig. 7-5, page 67.

Note: The Original Entry and Original Exit Sensors are not adjustable.

2.15 Check and Adjustment of Extended Thickness Sensor

See Fig. 2-12, page 29.

Adjustment:

Turn power OFF.

Remove Top Cover.

Locate the lock bracket on the left side of the Electronics Box.

Loosen the one T10 lock screw located in the bracket.

Open up the Electronics Box.

Turn power ON.



WARNING: The connector of the Lamp Cartridge is connected directly to the line voltage and constitute a risk of electric shock, or injury to persons.

Start SCANtest, Test 4

Open the Lid

Remove the Lid Cover

Remove Pressure Platen

1. Loosen the three fixing screws (two T20 and one T10) for the sensor bracket just enough to allow the bracket to be moved.
2. Set Thickness Adjustment Sliders to pos. 6 (step 2) at both sides, see Fig. 2-12.
3. Close Lid to lower the Idler Rollers to pos. 6.
4. Adjust the sensor bracket to position the sensor lever as close as possible to - but not touching - the pulley.
5. Tighten the three fixing screws (be careful to maintain the position of the bracket while tightening the fixing screws).
6. Check that the WAIT LED remains ON when opening and closing the Lid.
7. Set Thickness Adjustment Sliders to pos. 3 (step 1), see Fig. 2-12..
8. Close Lid while watching the Wait LED.
9. Check that the spacing between the Idler and Drive rollers is at least 1 mm when the WAIT LED turns OFF.

It may be necessary to repeat step 1 through 9 to obtain correct adjustment.

Check:

Start SCANtest, Test 4

Set Thickness Adjustment Sliders to pos. 6 (step 2).

Close Lid to lower the Idler Rollers.

Check that the WAIT LED remains ON.

Set Thickness Adjustment Sliders to pos. 3 (step 1).

Close Lid while watching the Wait LED.

Check that the spacing between the Idler and Drive rollers is at least 1 mm when the WAIT LED turns OFF.

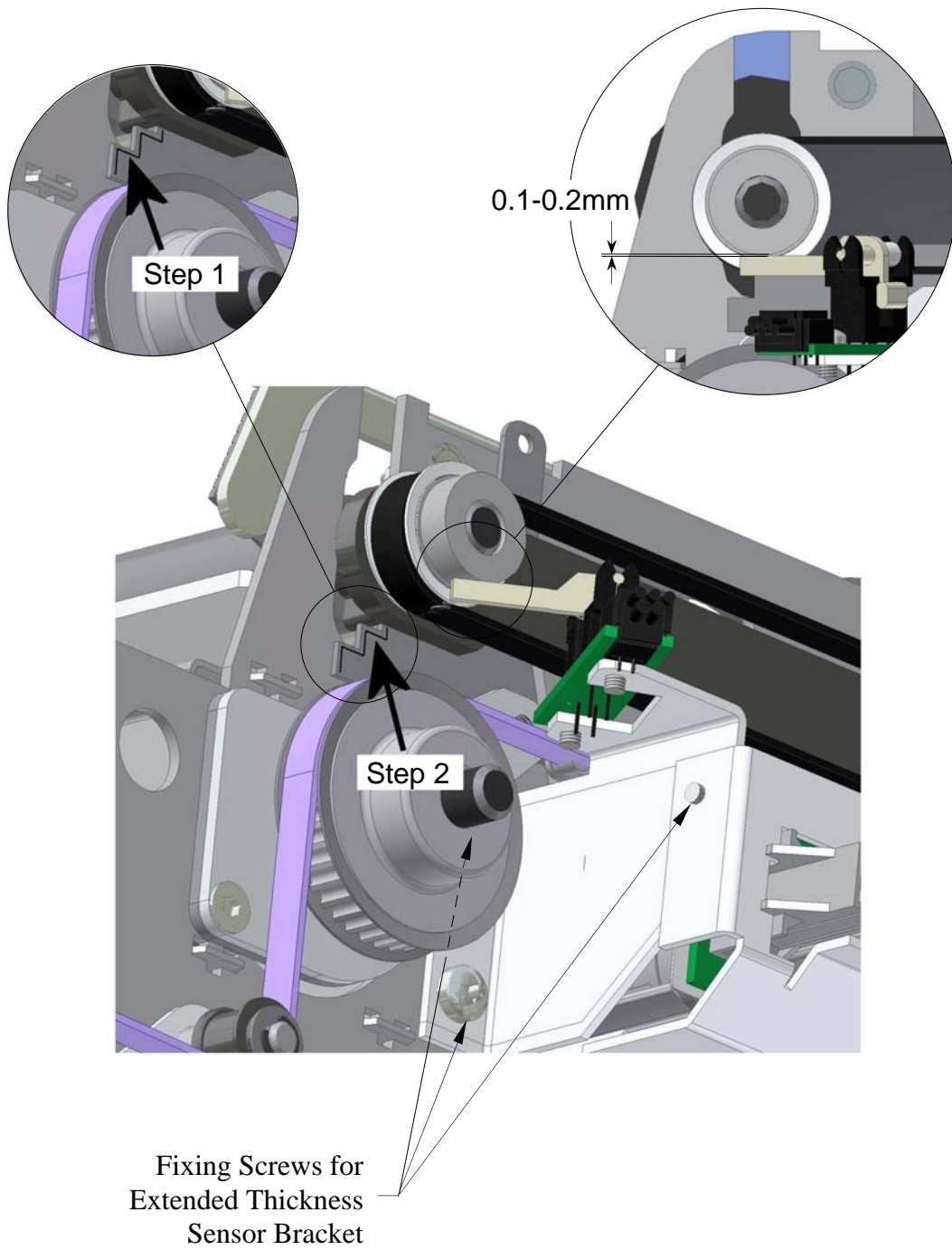

Fig. 2-12, Adjustment of Extended Thickness Sensor

3. CCD Camera

The adjustment procedures presented in this chapter cover all adjustments needed for replacing the complete CCD Camera.

It will hardly ever be necessary to replace mechanical parts such as Lens, Camera Housing, etc., and in most cases, the only adjustments necessary after replacement of the CBx-Board are:

- Check Scan-Width. If it is within the limits given in Section 3.2.3, page 38, then Focus will also be OK.
- CCD-Centering, Section 3.2.4, page 40.
- Vertical Positioning, Section 3.2.5, page 40.
- Run Scanner Maintenance, Section 4.1.3, page 46.

These adjustments can be made without loosening the Camera Fixing Screws and without loosening the Focus Lock Screw.

3.1 Description of CCD Camera

See Fig. 3-1, CCD Camera, page 32.

The CCD Camera basically consist of:

- Lens
- Lens Adapter
- Camera Housing
- Camera Back-Plate
- CCD Mounting Plate
- CBx-Camera Board
- Camera Base Plate
- Camera Guide Bracket
- EMC Cage

The parts of the CCD Camera are mounted on the Camera Base Plate, and the complete CCD Camera is mounted on a Mounting Platform, which is part the Mirror Chassis. The camera is positioned with the optical axis perpendicular to the scan-area by means of the Camera Guide Bracket placed at the left side of the camera.

The distance between the scanning area and the camera can be adjusted by loosening the three T20 Camera Fixing Screws and turning the Scan Width Adjustment Screw on the Guide Bracket.

Note: The Camera Base Plate and the Guide Bracket are connected by means of two screws with self-locking nuts. These two screws have been factory set to provide accurate and smooth guidance of the camera, and they should not be touched.

The Lens itself is mounted in the Lens Adapter, and three T6 screws secure its position in the adapter.

Slots in the Camera Housing allow the tube of the Camera Housing to be tightened around the Lens Adapter by means of a Focus Lock Screw, see Fig. 3-8, page 43. The slots are covered by a flexible Covering Tape to prevent stray light from entering the camera.

The Camera Housing can be tilted slightly up and down to position the scanline in the “vertical” direction by turning the Vertical Positioning Wheel.

Focus

The CCD Camera is focused by loosening the Focus Lock Screw and turning the Lens Adapter to get the maximal amplitude of the image of the Focus Pattern.

The Lens itself is mounted in the Lens Adapter, and three T6 screws secure its position in the adapter. When these screws are loosened, the lens can be rotated to have the dot on the lens pointing upwards. This is the “best position” as determined by the lens manufacturer.

This “best position” is not critical, and when doing field adjustments it will hardly ever be necessary to change the factory set position of the Lens.

Scan-Width

The Scan-Width depends on the distance between the CCD Camera and the scan-area. It can be adjusted by loosening the three T20 Camera Fixing Screws and turning the Scan Width Adjustment Screw to slide the CCD Camera back and forth to get the required number of Scan-Width Units within the field of vision, see Scan-Width Pattern, Fig. 3-9, page 44.

The scaling accuracy of the scanner depends directly on the accuracy of the Scan-Width adjustment.

Vertical Positioning and Centering of CCD Camera

To set the basic Vertical Position of the camera, adjust the Vertical Positioning Wheel to get 8 Black Lines of the Vertical Position Pattern, see Fig. 3-9, page 44.

The final positioning of the scanline within the scan-area is done by shifting the CCD Mounting Plate relative to the Camera Housing using the Vertical Tilt and CCD-Centering levers, see Fig. 3-8, page 43.

Fig. 3-2, page 33 shows the relation between the patterns on the Optical Adjustment Pattern and the waveforms seen on the screen of SCANtest, Test 9 during Camera Adjustment.

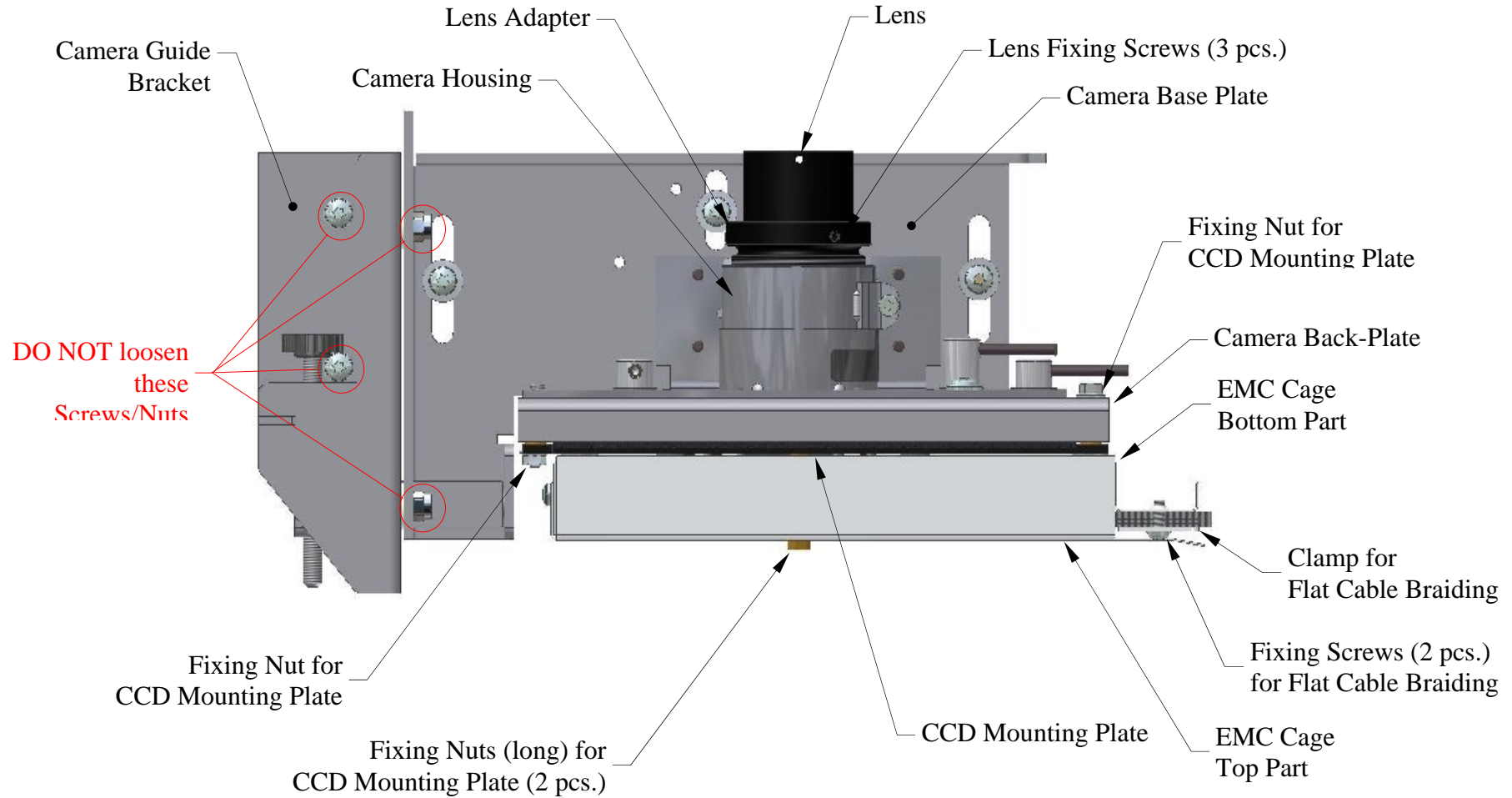

Fig. 3-1, CCD Camera

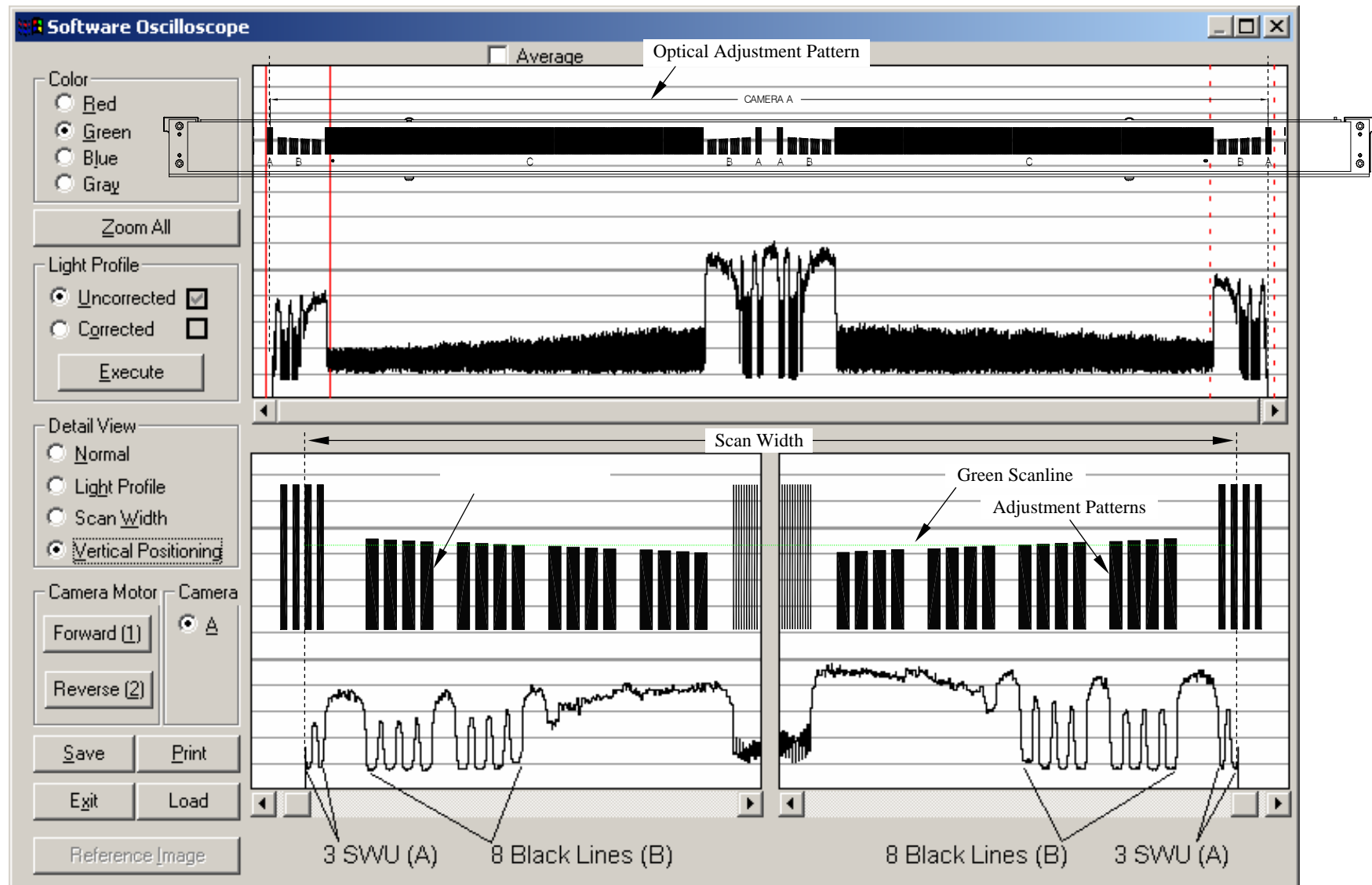

Fig. 3-2, Relations between Optical Adjustment Pattern and Screen Images

3.2 CCD Camera Check and Adjustment

Remove the Top Cover to get access to the CCD Camera.

Equipment needed:

- PC with SCANtest and Scanner Maintenance installed. IEEE 1394 or USB2.0 interface
- Optical Adjustment Pattern (6879A107)
- Focus Pattern (6779D216)

CCD Camera and adjustment tools are shown in:

Fig. 3-8, CCD Camera Overview (Adjustments), page 43

Fig. 3-9, Optical Adjustment Pattern, 36", page 44

Fig. 3-10, Focus Pattern, 40", page 45

In the description of the adjustment procedures, references are made to sub-patterns A, B, and C of the Optical Adjustment Pattern. These sub-patterns are shown in Fig. 3-9, page 44.

3.2.1 Check of Light Profiles

Images of the Light Profiles are shown in:

Fig. 3-3, Hx68A Uncorrected Light Profiles, page 35

Fig. 3-4, Hx68A Corrected Light Profiles, page 35

Procedure for check of Light Profiles

Place the Scan-area Lid in pos. 3 (Normal Media Thickness).

Start	SCANtest
Select	Test 9
Select	Uncorrected or Corrected Light Profile
Press	Execute
Select	Green (Default for Uncorrected)
Select	Detail View: Light Profile

Compare the image of the Software Oscilloscope with the relevant sample image listed above. If the signal levels of the uncorrected Light Profiles differ much from the sample images, the scanner might need to be calibrated by Scanner Maintenance.

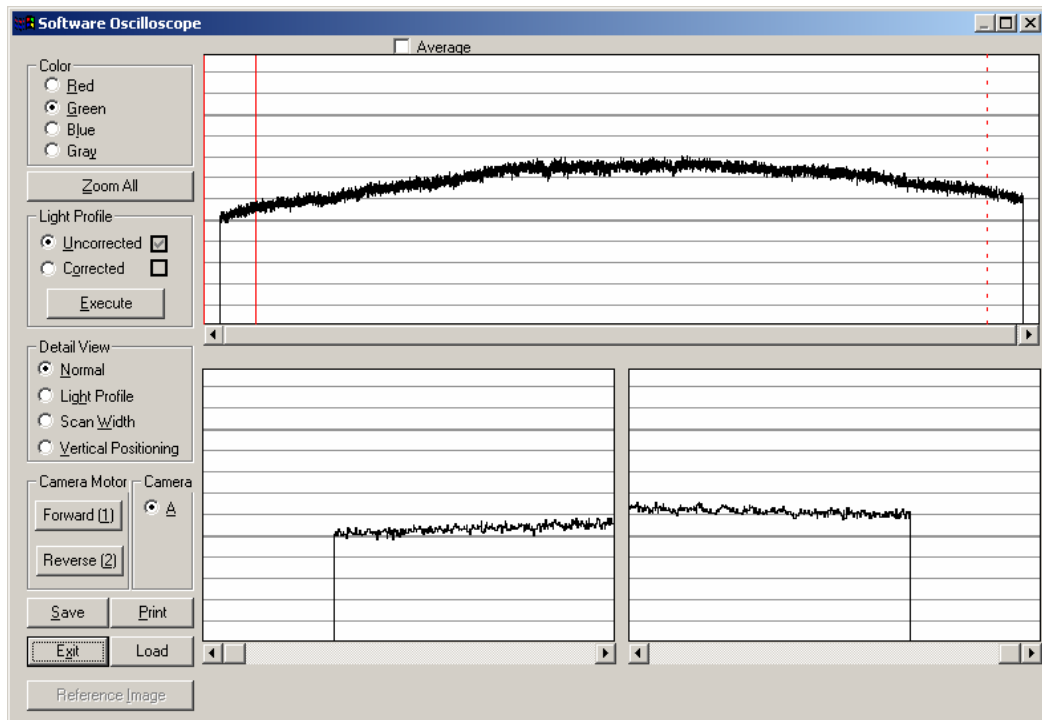

Fig. 3-3, Hx68A Uncorrected Light Profiles

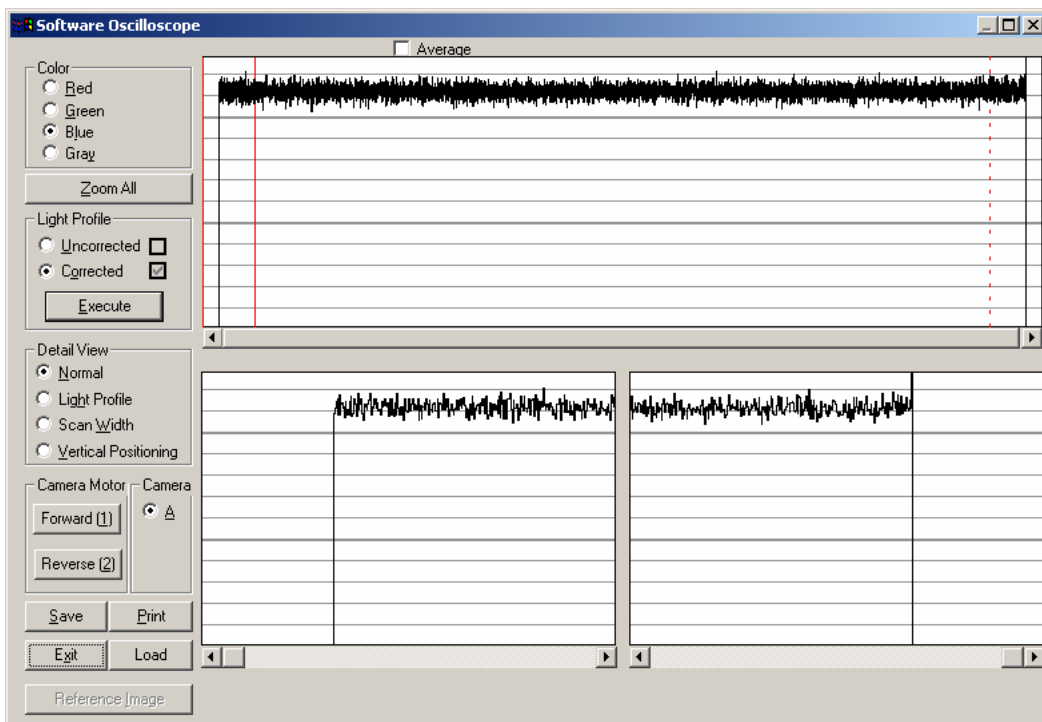

Fig. 3-4, Hx68A Corrected Light Profiles

3.2.2 Check and Adjustment of Focus

Images of the Focus adjustments are shown in:

Fig. 3-5, Hx68A Focus Signals, page 37.

Note: When replacing the Camera Board, it is normally not necessary to re-adjustment Focus. First check the Scan Width, and if it is OK, the Focus will also be OK.

Adjustment Procedure

Do not loosen the camera. The construction of the camera ensures that the optical axis of the lens is perpendicular to the scanning area and hence no alignment of the camera housing is necessary. Always perform the Focus adjustment before adjusting the Scan-Width, see “Interaction” below.

Start SCANtest
 Select Test 9
 Select Corrected Light Profile*)
 Press Execute

*) *Note:* If the camera is completely out of adjustment it may not be possible to run Test 9 in ‘Corrected’ mode. In that case, select ‘Uncorrected’ and with the Optical Adjustment Pattern placed in the scan-area make a coarse adjustment of Focus and Scan-Width before continuing.

Select Blue (Default)
 Select Detail View: Light Profile

Insert the Focus Pattern and feed it by using the Forward Key until the image of the pattern with the resolution listed below is seen on the upper image on the screen:

Model	Focus Pattern	Resolution
HA68A	6779D216	1.5 lp/mm
HB68A	6779D216	1.5 lp/mm

Loosen the Focus Lock Screw (see Fig. 3-8, page 43) and turn the Lens Adapter to get maximum amplitude of the Focus signal (approximately 6 division peak-to-peak).

The amplitude of the Focus signal (Corrected) should be even within:

$$\text{Min/Max} > 0.7$$

Tighten the Focus Lock Screw to secure the Focus setting.

Interaction

The Focus adjustment has a big influence on the Scan-Width adjustment. Therefore the Scan-Width must be checked and readjusted if necessary when the Focus adjustment has been changed. On the other hand, the Focus adjustment is relative tolerant to changes in the Scan-Width adjustment and as a rule of thumb, the Scan-Width adjustment can be changed ± 1 SWU without the need for re-focusing.

When all camera adjustments have been completed, run Scanner Maintenance.

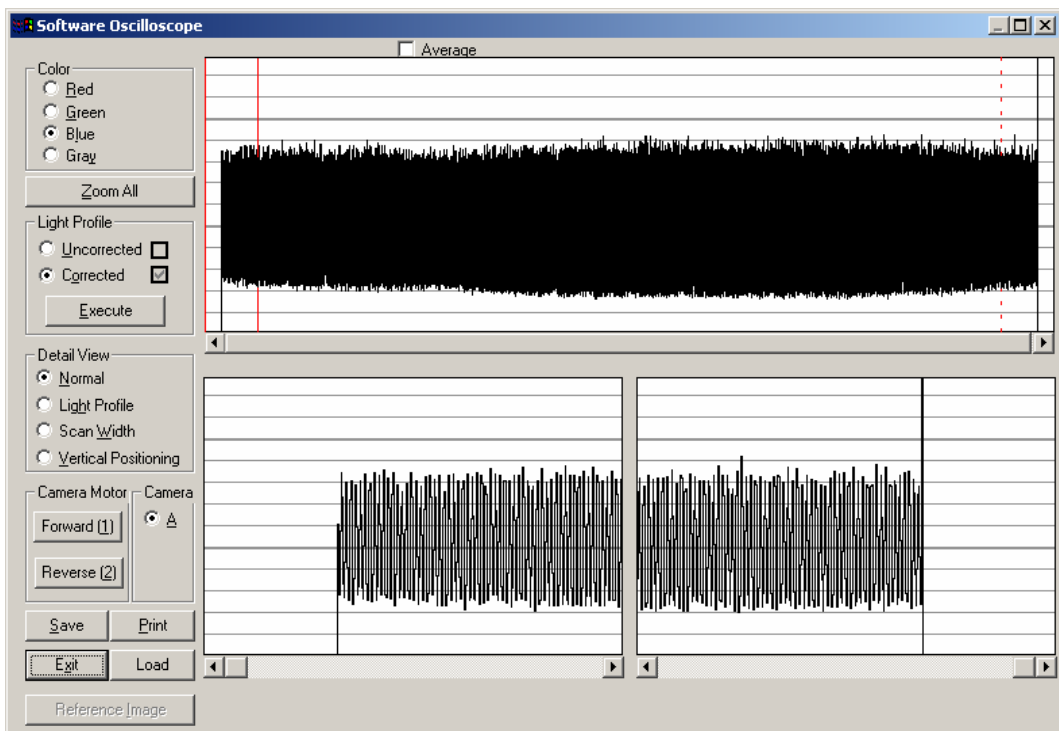

Fig. 3-5, Hx68A Focus Signals

3.2.3 Check and Adjustment of Scan-Width

Images of the Scan-Width adjustments are shown in:

Fig. 3-6, Hx68A Scan-Width, page 39

The aim of this adjustment is to obtain a camera Scan-Width of:

HA68A:	914.4 mm
HB68A:	914.4 mm

The Scan-Width is correct if the total sum of Scan-Width Units (SWU) at the start and at the end of the scanline is as shown in the table below (*1 SWU is either 1 Black Line or 1 White Space of the Scan-Width Pattern (A)*).

Model	Optical Adjustment Pattern	Total sum of Scan-Width Units	Tolerance
HA68A	6879A107, sub-pattern A	6	± 1 SWU
HB68A	6879A107, sub-pattern A	6	± 1 SWU

The tolerance corresponds to approximately 0.10% on the Scan-Width (scaling error).

Adjustment Procedure

Always do the Focus adjustment before adjusting the Scan-Width, see “Interaction” below.

Place the Optical Adjustment Pattern (see table above) in the scan-area.

Align the Adjustment Pattern by pushing it sideways towards the Operator Panel and towards the front of the scanner.

- Start SCANtest
- Select Test 9
- Select Uncorrected Light Profile
- Press Execute
- Select Green (Default)
- Select Detail View: Scan Width

Loosen the three T20 Camera fixing screws and the three T20 Camera Back-Plate fixing screws (use special key, p/n 0008V354), see Fig. 3-8, page 43. The screws should be loosened just enough to allow the Camera and the Camera Back-Plate to be moved.

Adjust the Scan-Width by turning the Scan-Width Adjustment Screw (which moves the Camera back and forth) to get the correct total sum of Scan-Width Units, see the table above (at least 1 black line must be clearly visible at the start as well as at the end of the scanline).

One full turn of the Scan-Width Adjustment Screw changes the Scan-Width approximately 0.7 SWU.

Interaction

Check Focus and readjust if necessary.

The Focus adjustment has a big influence on the Scan-Width adjustment. Therefore the Scan-Width must be checked and, if necessary, readjusted when the Focus adjustment has been changed. On the other hand, the Focus adjustment is relative tolerant to changes in the Scan-Width adjustment and as a rule of thumb, the Scan-Width adjustment can be changed ± 1 SWU without the need for re-focusing.

When all camera adjustments have been completed, run Scanner Maintenance.

Note

The horizontal (X-axis) accuracy of the scanner depends on the distance between camera and scan-area.

Scaling errors may be corrected as follows:

If the scanned image is too big:

Turn the Scan-Width Adjustment Screw CCW (increase the Scan-Width).

If the scanned image is too small:

Turn the Scan-Width Adjustment Screw CW (decrease the Scan-Width).

The Scan-Width Adjustment Screw should be turned approx. 1 turn per 0.1% error.

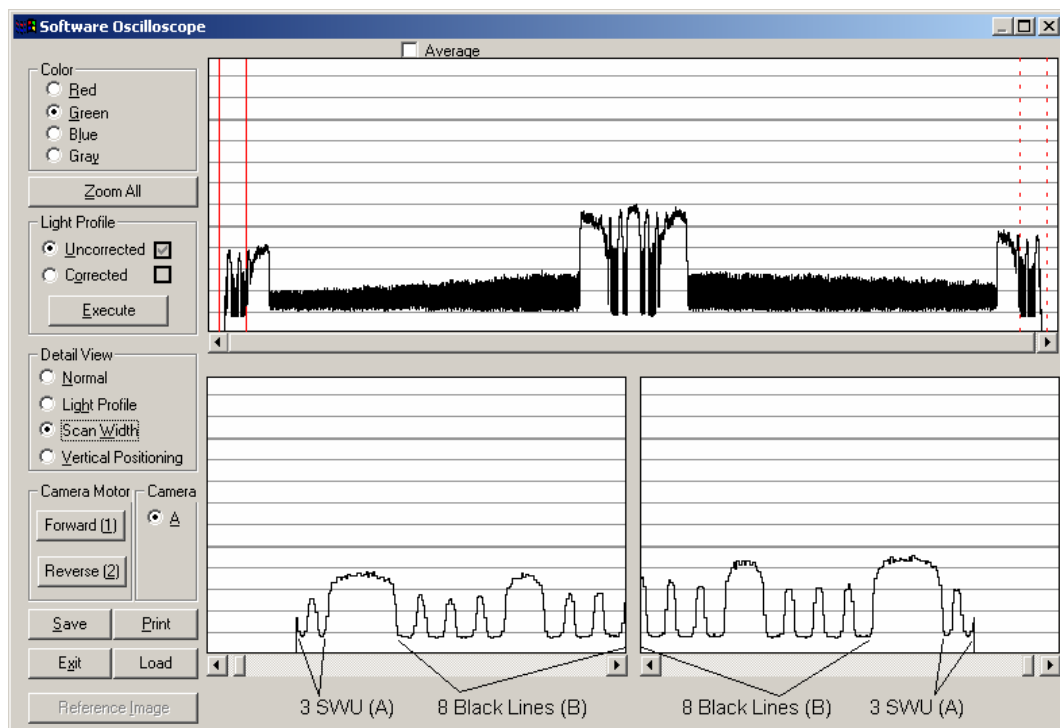

Fig. 3-6, Hx68A Scan-Width

3.2.4 Check and Adjustment of CCD-Centering

Images of the CCD-Centering adjustments are shown in:

Fig. 3-7, Hx68A CCD-Centering and Vertical Positioning, page 42.

The aim of this adjustment is to position the field of vision of the CCD Camera symmetrically with respect to the Scan-Width Adjustment Patterns.

The Black Lines and White Spaces of the Scan-Width Patterns should be distributed symmetrically with the following number of Scan-Width Units at both ends of the scanline:

Model	Optical Adjustment Pattern	No of Scan-Width Units, start	No of Scan-Width Units, end	Tolerance
HA68A	6879A107, sub-pattern A	3	3	± 2 SWU
HB68A	6879A107, sub-pattern A	3	3	± 2 SWU

The tolerance on the CCD-Centering means that the image may be shifted ± 2 SWU.

Note: The total number of Scan Width Units must be 6 ± 1 , see Section 3.2.3, page 38.

Adjustment Procedure

Place the Optical Adjustment Pattern (see table above) in the scan-area.

Align the Adjustment Pattern by pushing it sideways towards the Operator Panel and towards the front of the scanner.

Start	SCANtest
Select	Test 9
Select	Uncorrected Light Profile
Press	Execute
Select	Green (Default)
Select	Detail View: Scan Width

Loosen the three T20 Camera Back-Plate fixing screws (use special key, p/n 0008V354), see Fig. 3-8, page 43, the screws should be loosened just enough to allow the Camera Back-Plate to be moved.

Adjust the horizontal position of the Camera Back-Plate by means of the CCD Centering Lever until the oscilloscope image shows the correct number of Scan-Width Units of the actual sub-pattern at the start and at the end of the scanline.

Tighten the Camera Back-Plate fixing screws.

Interaction

Check Vertical Position.

After completing all camera adjustments, run Scanner Maintenance.

3.2.5 Check and Adjustment of Vertical Positioning

Images of the Vertical Positioning adjustments are shown in:

Fig. 3-7, Hx68A CCD-Centering and Vertical Positioning, page 42.

The aim of this adjustment is to place the scanline in the correct “Vertical Position” within the scan-area, and to ensure that the scanline is “horizontal”.

The Vertical Positioning of the CCD Cameras is based on the number of black lines of the Vertical Position Pattern that crosses the scanline (the Vertical Position Pattern is sub-pattern B of Fig. 3-9, page 44). The step height of the Black Lines in the Vertical Position Pattern is shown in the table following:

Model	Optical Adjustment Pattern	Step Height of Black Lines	Step Height 0 through 16 Black Lines
HA68A	6879A107, sub-pattern B	0.15 mm	2.25 mm
HB68A	6879A107, sub-pattern B	0.15 mm	2.25 mm
HC68A	6879A107, sub-pattern B	0.15 mm	2.25 mm

The cameras are adjusted to 8 Black Lines of the Vertical Position Pattern at both ends of the scanlines.

Adjustment Procedure

Place the Optical Adjustment Pattern (see table above) in the scan-area.

Align the Adjustment Pattern by pushing it sideways towards the Operator Panel and towards the front of the scanner.

Start	SCANtest
Select	Test 9
Select	Uncorrected Light Profile
Press	Execute
Select	Green (Default)
Select	Detail View: Vertical Positioning

Loosen the three T20 Camera Back-Plate fixing screws (use special key, p/n 0008V354). The screws should be loosened just enough to allow the Camera Back-Plate to be moved.

Adjust the Vertical Tilt Levers to get 8 Black Lines of the Vertical Position Patterns at both ends of the scanline, and at the same time maintain correct CCD-Centering.

If 8 Black Lines at both ends can not be obtained:

Set the Vertical Tilt Levers to their nominal positions, that is, horizontal position for the lever near the “connector end” of the camera board and vertical position for the other lever.

Adjust the Vertical Positioning Wheel to get approximately 8 Black Lines at both ends of the scanline.

Adjust the Vertical Tilt Levers to get 8 Black Lines of the Vertical Position Patterns at both ends of the scanline, and at the same time maintain correct CCD-Centering.

Tighten the Camera Back-Plate fixing screws, while maintaining the 8 Black Lines at both ends of the scanline.

Tolerances:

The cameras should be adjusted to 8 Black Lines of Vertical Position Pattern at both ends of the scanlines.

For maintenance check the adjustment is considered acceptable if the number of Black Lines of the Green channel is within:

max. 12 Black Lines
min. 4 Black Lines

The sloping of a scanline, i.e. the difference in the number of Black Lines at the **start** and at the **end** of the scanline must be less than:

2 Black Lines

Interaction

After completing all camera adjustments, run Scanner Maintenance.

3.2.6 Final Check

As the above adjustments interact:

Check, and if necessary readjust steps 3.2.2 through 3.2.6

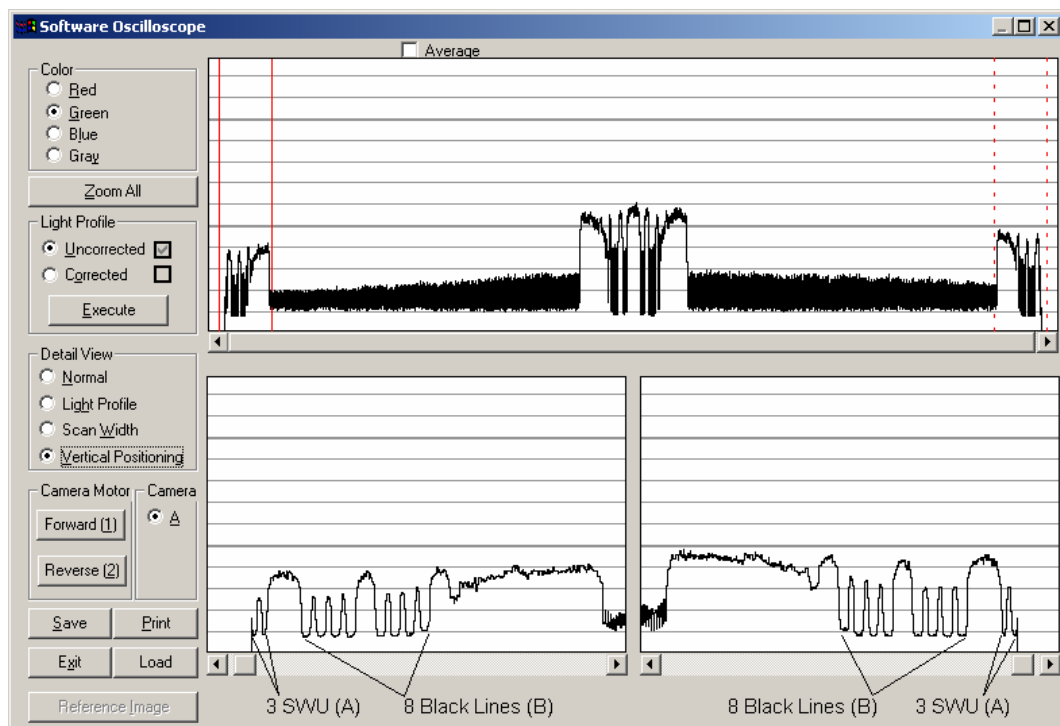

Fig. 3-7, Hx68A CCD-Centering and Vertical Positioning

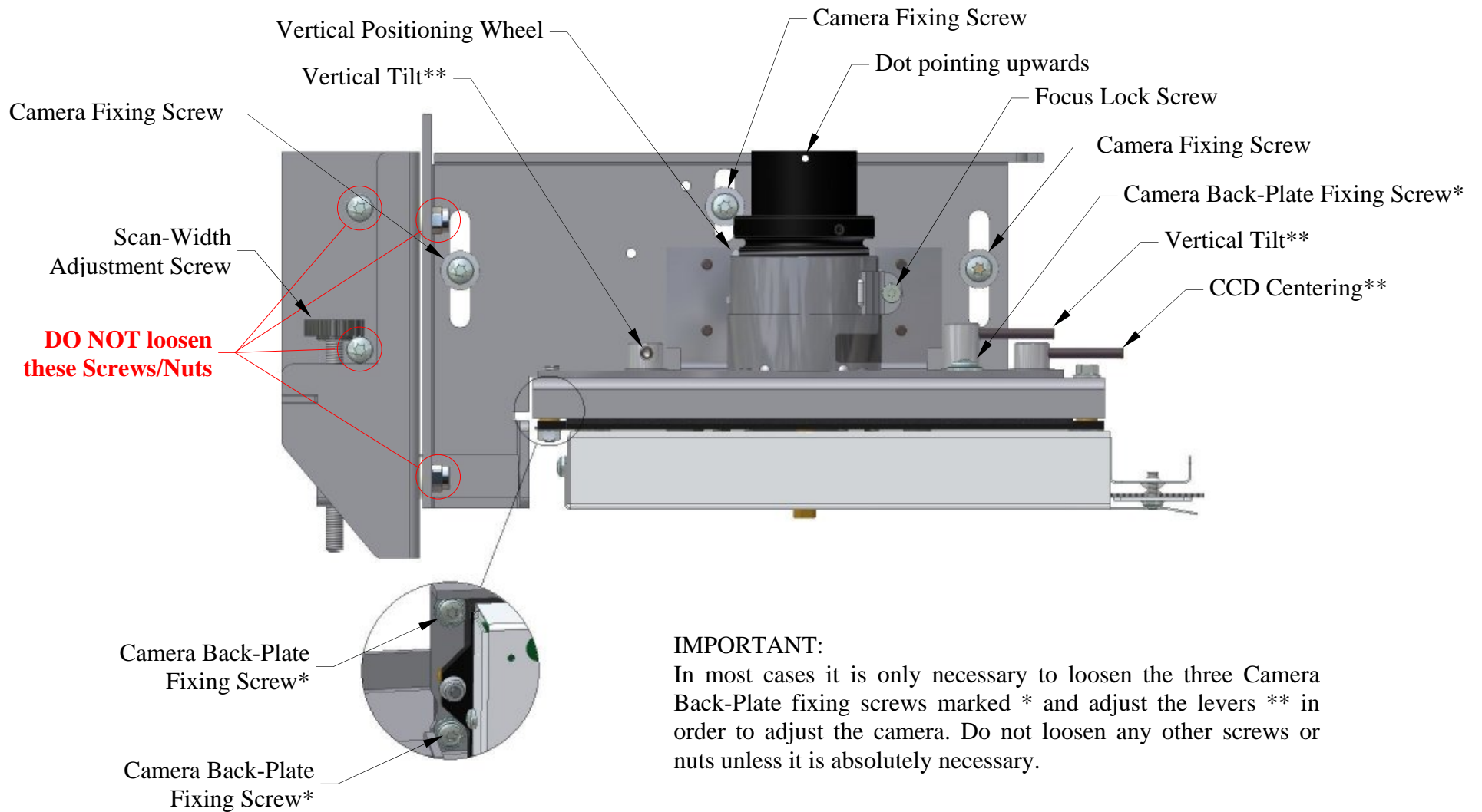
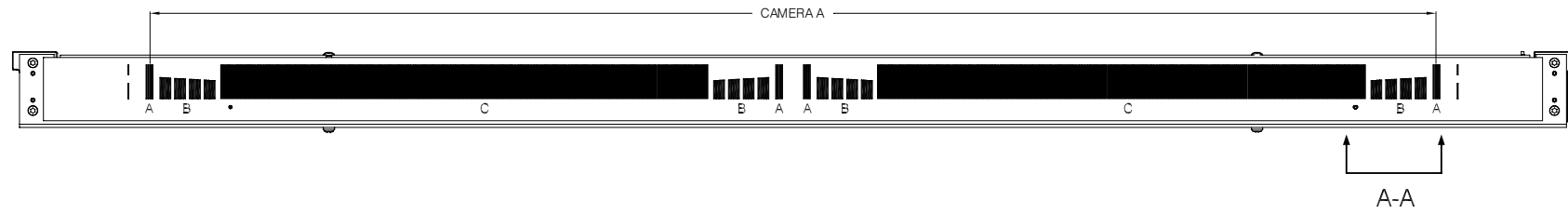

Fig. 3-8, CCD Camera Overview (Adjustments)



- Sub-pattern A: Scan-Width Patterns
- Sub-pattern B: Vertical Position Patterns
- Sub-pattern C: Focus Pattern (used for coarse Focus adjustment)

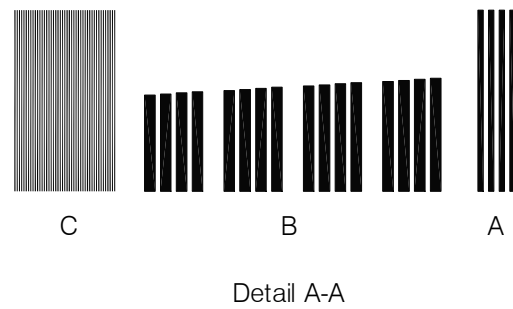
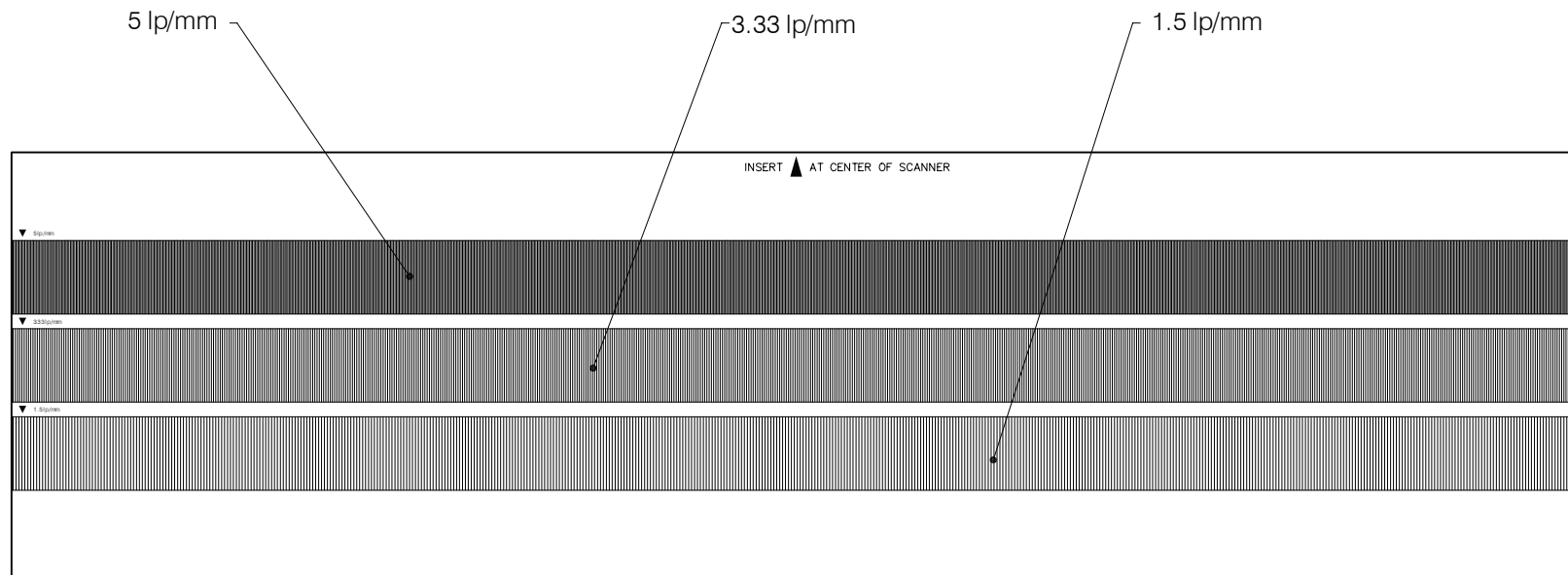

Fig. 3-9, Optical Adjustment Pattern, 36"



Upper Pattern: 0.1mm black lines with 0.1mm spacing (5 lp/mm)

Center Pattern: 0.15mm black lines with 0.15mm spacing (3.33 lp/mm)

Lower Pattern: 0.4mm black lines with 0.4mm spacing (1.5 lp/mm)

Fig. 3-10, Focus Pattern, 40"

4. General Maintenance

General Maintenance consists of the following steps:

- Clean the scanning area.
- Check Camera Adjustment.
- Run Scanner Maintenance.

For special service tools for General Maintenance, please refer to Chapter 10, page 77.

4.1 Step by Step Procedure for General Maintenance

4.1.1 Clean the Scanning Area

- Turn the scanner power OFF and disconnect the power plug.
- Remove Top Cover.
- Clean the White Background Pressure Platen.
- Clean both sides of the Glass Plate.
- Clean the Mirrors.
- The location of the mirrors is shown in Fig. 7-7, page 69.

The above parts are cleaned using a soft lint-free cloth wetted with a mild cleaning detergent. Alternatively, the parts may be cleaned without the use of cleaning detergents by using a damp microfibre cleaning cloth (wet the cloth with water and wring until damp).

- Clean the Feed Rollers. May be cleaned with a damp microfibre cleaning cloth.

4.1.2 Check CCD Camera Adjustment

Procedure for Check and Adjustment, see Section 3.2, page 34.

If necessary re-adjust the camera.

Caution: Before loosening any Camera Fixing screws or Focus Lock screw, make sure that all necessary Adjustment Patterns are available.

Replace Top Cover.

4.1.3 Run Scanner Maintenance.

The SM Calibration Sheet is shown in:

Fig. 4-1, SM Calibration Sheet, 42", page 47

To avoid vertical lines in the scanned image, the Glass Plate and the White Background (Pressure Platen) must be thoroughly cleaned before running Scanner Maintenance, see SCANtest, Test 20, Noise Test on page 73.

Procedure:

Start	Scanner Maintenance
Insert	SM Calibration Sheet

Follow the instructions given on the screen.

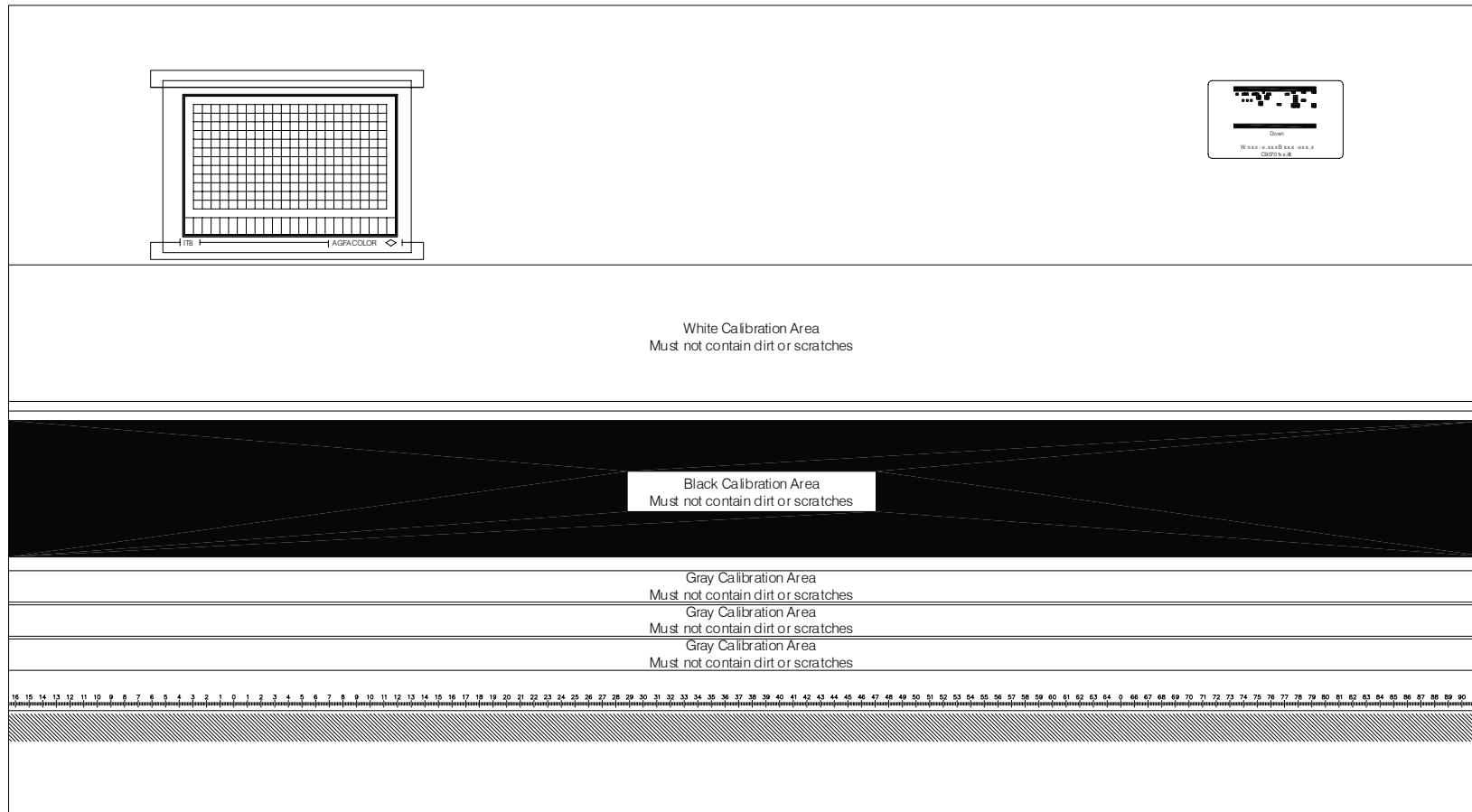

IT8-Sheet and patterns faces outwards when folded

Fig. 4-1, SM Calibration Sheet, 42"

5. Troubleshooting

If contacting Contex for support always supply the following information:

Scanner Model
 Serial Number
 Firmware revision
 Description of the problem
 ScanDump of Light Profiles

5.1 Power-On Self-Test

The following operations are executed when the scanner is switched ON:

Operation	Description
Check Scanner ID	Checks if the setting of the DIP switch on the Operator Panel is valid. Check if Smart Card is valid for the scanner type. All Indicators are ON.
Hardware Self-Test	Checks LMx, SUx-, CBx -, and IMx -Boards. All Indicators are ON
Start stepper motor to position Original	Tries to position the Original if one of the Original Sensors is activated and not in Extended Thickness mode. If Entry and Exit sensors both are activated or the Scan-area Lid is in Extended Thickness mode paper is not moved. Power and Wait Indicators are ON.
Warm Up	Normally the Warm-Up time is app. 3 minutes. The Warm-Up time can be skipped by pressing the Forward and Reverse keys simultaneously. Power and Wait Indicators are ON.
Light Profile Correction	The Light Profile is Corrected at power-on, Power and Wait Indicators are ON. Thereafter the Light Profile is Corrected whenever the scanner is idle and the Scan-area Lid is down in Normal position. If a required Light Profile Correction is suspended (Extended Thickness) the Wait Indicator flashes.

5.2 LED Indicators on Operator Panel

Power LED (Green and Red)	
Booting	Green
Power-On-Self-Test	Yellow (Green & Red ON)
Warm Up	Green
Power ON (Operating mode)	Green
Low Power mode (Sleep mode)	Red
Scanner in Test mode (SCANtest)	OFF

Diagnostic LED (Red)	
Booting and Power-On-Self-Test:	Red
Warm Up	OFF
Normal Operation	OFF
Scanner in Test mode (SCANtest)	Red
Error Condition, see Section 5.3.2 below.	Flashing

Wait LED (Yellow)	Media Thickness Setting	
	Normal	Extended Thickness
Booting and Power-On-Self-Test:	Yellow	Yellow
Warm Up	Yellow	Yellow
Normal Operation:	OFF	OFF
Automatic update of Light Profile Correction has been suspended for a period exceeding the built-in update-timer or the scanner has been switched ON with the Scan-area Lid set for Extended Thickness.	Flashing Hint: May also occur during intensive scanning in batch mode or if original Exit and Entry Sensors are both activated during power on.	Flashing Hint: Lower Scan-area Lid to Normal position to allow Light Profile Correction to be done.
Error Condition, Diagnostic is flashing, see Section 5.3.2 below.	Flashing	Flashing

Ready LED (Green and Red)	Media Thickness Setting	
	Normal	Extended Thickness
Booting and Power-On-Self-Test:	Yellow (Red & Green ON)	Yellow (Red & Green ON)
Warm Up	OFF	OFF
No media	OFF	Red
Media inserted	Green	Yellow (Red & Green ON)
Scanning	Flashing Green / OFF	Flashing Yellow / Red
Error Condition: Diagnostic LED is flashing, see Section 5.3.2 below.	Flashing Green / OFF	Flashing Green / OFF or Yellow/Red

5.3 Error Codes

5.3.1 Error Codes displayed on the Operator Panel

A flashing Diagnostic Indicator indicates an error condition. The error may be identified by an Error Code Number being displayed on the screen and/or by the following combinations of flashing (F) indicators on the Operator Panel:

Diagnostic	Wait	Ready	Error Description
F	1 x F	OFF	Correction of Camera A failed
F	OFF	1 x F	Error on SUx-Board
F	OFF	2 x F	Error on CBx -Board
F	OFF	3 x F	Invalid Scanner ID setting
F	OFF	4 x F	Error on IMx-Board
F	OFF	5 x F	Invalid Smart Card
F	F	F	Scanner is in Boot Mode
F	OFF	OFF	Refer to the Section below

1 x F, 2 x F, ... means that the Wait and/or the Ready Indicator flashes 1, 2, ... times every time the Diagnostic Indicator is turned ON.

F, F, F means that all three indicators flash simultaneously.

5.3.2 Error Codes displayed on the PC Screen

If SCANtest is started when the scanner is in Error condition it will display the Error Code Number and a short description of the error.

Please refer to Appendix A, Error Codes page 78 for a list of error codes

5.4 Troubleshooting Hints

The scanner does not power-up

- Check the power supply connections.
- Check that all cable connectors are properly inserted into their sockets.
- Check voltages on the SMPS.
- Check the supply voltages on the LMF-, CBx-, IMx, and SUx-Boards.

Error 100-8147, 'Invalid Scanner ID'

- Error 08-147 indicates that the DIP Switch (pos. 4, 5, 6, 7, and 8) on the Operator Panel is set to an undefined scanner type or inconsistency between the detected scanner hardware and the Scanner ID switch setting, see Section 2.12.4, page 24.
- Error 08-147 may also indicate a bad connection between the SUx-Board and the Operator Panel.

Error 100-8149, Invalid Smart Card

- The Smart Card is not valid for this scanner type.
- Error 08-149 may also indicate a bad connection between the SUx-Board and the Smart Card Reader.

Error 100-8208, Keyboard check failed

- Check cable to Operator Panel.
- Replace Operator Panel.

Error 100-8220, Lamp Cartridge Detached

- Push the Lamp Cartridge back into its socket.

Error 100-128, Paper Jam

Error 100-1006, Paper Jam

When scanning at max speed (10 inch/sec) the stepper motor is running beyond its "pull -in rate" and it may not be able to restart if it for some reason stops. This situation will be detected by the tacho device, and the motor will be turned OFF.

- Remove the jammed original.
- If the original is not jammed, lower the scan speed (WIDEimage) and start a new scanning.

Error 100-30140, Light Profile Correction Failed (Color Channels)

Error 100-30240, Light Profile Correction Failed (B/W Channel)

Error 30 is displayed if a larger number of pixels cannot be adjusted up to the required White-Signal Level.

- Error 30 is most often caused by dirt on the Glass Plate or the White Background Plate and the first step should be to make sure that these parts are clean.
Next, use SCANtest, Test 9, to check the Light Profiles, see Section 3.2.1, page 34.

If the Light Profile is distorted, the cause may be:

- Incorrect Vertical Positioning, see Section 3.2.5, page 41.
- Lamp does not turn ON.
- Corrupted Basic Calibration.
Try to Erase Parameter Blocks, see Section 2.2.1, page 7. Remember to run Scanner Maintenance after Erase Parameter Blocks.
- Defective CBx-Board.

It is possible to override Error 30 from WIDEimage and go through with the scanning. Whether the result will be useful or not depends on the actual cause of Error 30.

Error 100-40035, 40039, 40043, 40047, 40075, 40076, 40084, CBx-Board Errors

- Check that the Lamp is lit.
- Run SCANtest, Test 7 to verify the error.
- Check that all cable connectors are properly seated into their sockets.
- Check that no cables have been interchanged.
- Check the supply voltages on the boards.
- Replace CBx-Board.

Error 100- 400134 to 400139, 400170,400174, 400178, 400182, 400186, CBx-Board Errors

- Run SCANtest, Test 7 to verify the error.
- Check that all cable connectors are properly seated into their sockets.
- Check the supply voltages on the boards.
- Check Light Profiles with SCANtest, Test 9, see Section 3.2.1, page 34.
- Erase Parameter Blocks, see Section 2.2.1, page 7.
- Run Scanner Maintenance.
- Replace Lamp Cartridge.
- Replace CBx-Board.

Error 100-50017 to 50028, 50051 to 50081 and 50090 to 50099, SUx-Board Errors

- Run SCANtest, Test 7 to verify the error.
- Check that all cable connectors are properly seated into their sockets.
- Check the supply voltages on the board.
- Replace SUx-Board.
- Run Scanner Maintenance.

Error 100-50100 to 50217, Firmware related errors

- Upgrade firmware.
- Erase Parameter Blocks, see Section 2.2.1, page 7.
- Run Scanner Maintenance.

Error 100-60029 to 60034, 60082 to 60085, IMx-Board Errors

- Run SCANtest, Test 7 to verify the error.
- Check the supply voltages on the IMx-Board.
- Replace IMx-Board.

Error 100-3062, Fan Error

- Check that fan cable is connected and that the fan is not blocked.
- Check supply voltage on the LMF-Board, Section, 2.4, page 10.
- Replace Fan.
- Replace LMF-Board.

Note: If the Fan has been disconnected or temporarily blocked, the scanner must be switched OFF/ON to restart the Fan.

Error 100-20221, LMx Board Error

- Check supply voltage on the LMF-Board, Section, 2.4, page 10.
- Check flat cable between SUx- and LMF-Boards
- Replace LMF-Board.

Note: Checks communication link between SUx- and LMF- Boards

Original Feed Problems

If the Stepper Motor does not run:

- Check supply voltage on the SMPS and LMF-Board, Section 2.3, page 8 and Section, 2.4, page 10.
- Replace LMF-Board.
- Remove the Stepper Motor cable connector from J10 on the LMF-Board and check the resistance of the two windings of the Stepper Motor:
 - Winding 1: Blue – Brown (Green)
 - Winding 2: Yellow - RedThe resistance should be approximately 3.7 ohms.
- Replace Motor.

Streaking (Vertical Lines)

Vertical Lines running from top to bottom of the scanned image are often caused by dust or dirt on the Glass Plate.

A description of how to locate the cause of vertical lines in the scanned image is given in:

Section 8.1.11, Test 20, Noise Test, page 73.

If it has been necessary to remove a CBx-Board for cleaning of the CCD-chip, refer to Chapter 3, page 30 for adjustment instructions.

6. Disassembly and Assembly

Refer to the following figures:

Fig. 6-1, Lid Cover, page 56.

Fig. 6-2, Disassembly, page 57.

Fig. 7-1, Cable Routing, page 63.

CAUTION:

Before removing any covers, turn the power switch OFF and disconnect the power cord.

Note:

All screws are Torx, the following sizes are used:

T6 (set screws in pulleys)

T10 (general)

T20 (general)

T30 (Fixing screws for Mirror Chassis)

The following Sections describe disassembly. For assembly, use the same procedures in reverse order.

6.1 Lid Cover

Fig. 6-1, page 56.

Open up the Scanning Area Lid and remove the four T20 fixing screws.

Remove the Lid Cover.

6.2 Top Cover

Fig. 6-2, page 57.

Remove the Lid Cover.

Pull out the Smart Card.

Remove the two Thickness Adjustment Sliders.

Remove the six fixing T20 screws located in raised holes from the Bottom Cover.

NB! Do not touch the four screws flush with the Bottom Cover (they are for the scanner chassis).

Click the Top Cover off the spring locks along the edge of the cover.

Lift off the Top Cover.

6.3 Electronics Box

Fig. 6-2, page 57.

Remove Top Cover.

Locate the lock bracket on the left side of the Electronics Box.

Loosen and remove the T10 lock screw located in the bracket.

Open up the Electronics Box.

Remove the clamp for the camera cable.

Remove the one T20 fixing screw for the EMC Ferrite (Lamp Cartridge cables).

Remove the three T20 fixing screws for the EMC connection bracket.

Remove the eighteen T10 fixing screws for the bottom cover plate.

Note the routing of the cables for later re-installation, see Fig. 7-1, page 63.

Pull the cables out of the cable clips / clamp.

Remove the bottom cover plate.

Unplug all cables leaving the Electronics Box.

Remove four T20 fixing screws for Electronics Box from the Bottom Cover.

Lift out the Electronics Box.

6.4 Scanner Chassis

Fig. 6-2, page 57.

To remove the Scanner Chassis from the Bottom Cover:

Remove Top Cover.

Open Electronics Box and remove bottom cover plate.

Unplug all cables leaving the Electronics Box.

Remove four T20 fixing screws (all except the two at the ends) of the spring lock rail along the front edge of the Bottom Cover.

Remove the four T20 fixing screws for the Scanner Chassis (flush with the Bottom Cover).

Lift out the Scanner Chassis.

6.5 Mirror Chassis

Fig. 7-7, page 69.

Remove Scanner Chassis from Bottom Cover.

Remove clamps for camera cable.

Remove the three T20 fixing screws for the Camera assembly.

Remove the two T20 fixing screws for the Camera Guide Bracket.

Remove the Camera assembly with Guide Bracket.

Remove the three T30 fixing screws for the Mirror Chassis, two at the left side and one at the right side (motor side) of the chassis.

Pull out the Mirror Chassis.

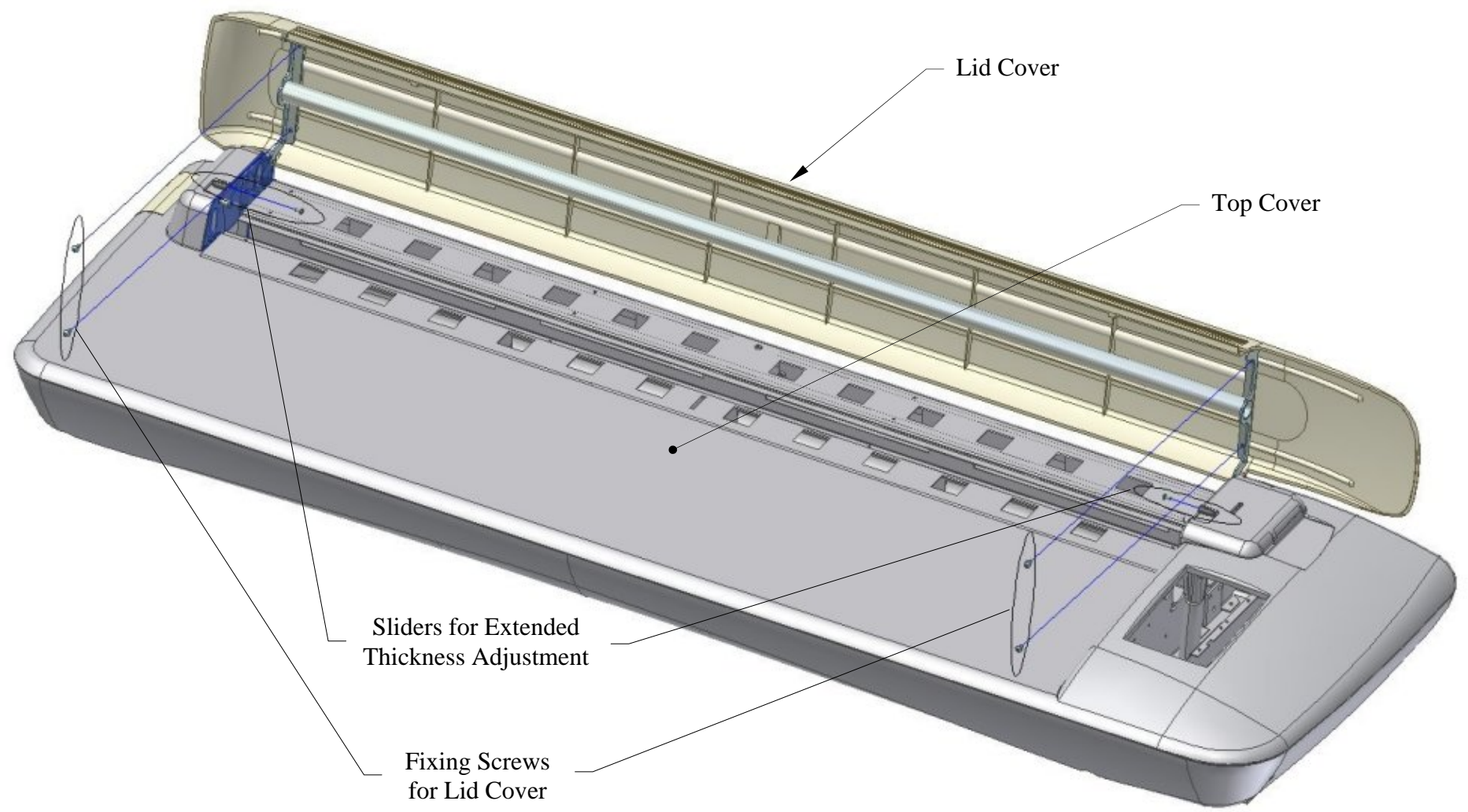

Fig. 6-1, Lid Cover

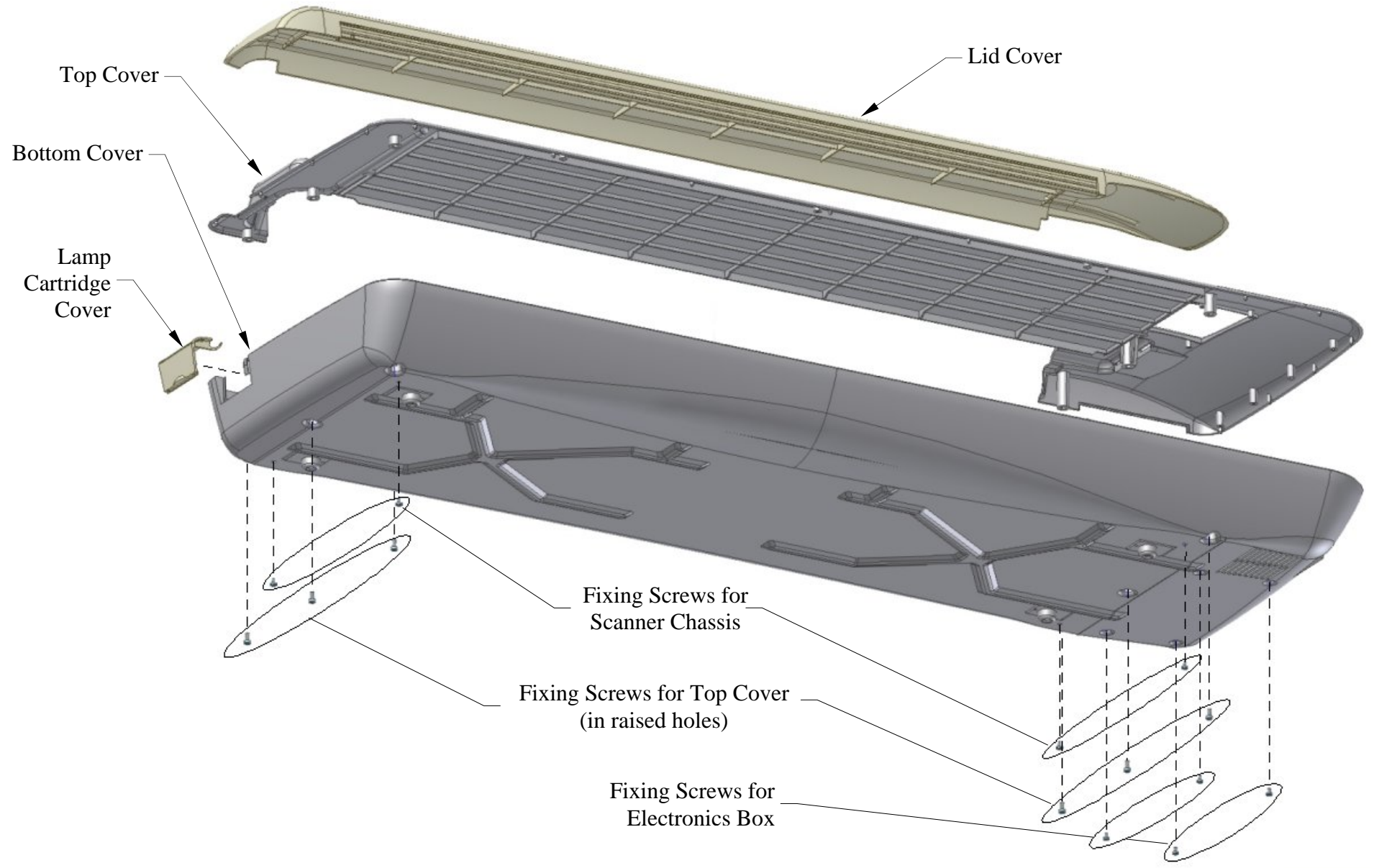

Fig. 6-2, Disassembly

7. Replacement of Parts

Refer to the following figures:

- Fig. 7-1, Cable Routing, page 63.
- Fig. 7-2, Inside Electronics Box, page 64.
- Fig. 7-3, Stepper Motor, page 65.
- Fig. 7-4, Drive-Belt Tightener Adjustment, page 66.
- Fig. 7-5, Paper Sensors, page 67.
- Fig. 7-6, Drive System, page 68.
- Fig. 7-7, Scanner Cross Section, page 69.

CAUTION:

Before removing any covers, turn the power switch OFF and disconnect the power cord.

The following Sections describe removal of parts. For replacement, use the same procedures in reverse order.

7.1 SUx- Board and IMx-Board

The SUx-Board and IMx-Board are located in the upper part of the Electronics Box, see Fig. 7-2, page 64.

Remove Top Cover.

Locate the lock bracket on the left side of the Electronics Box.

Loosen and remove the T10 lock screw in the bracket.

Open up the Electronics Box.

Note the routing of the cables for later re-installation, see Fig. 7-1, page 63.

Pull the cables out of the cable clips.

Remove the seven T10 fixing screws for the upper cover plate.

Remove the upper cover plate to get access to the boards.

Note: When closing the Electronics Box, be careful to arrange all cables correctly and make sure that no cables get jammed, see Fig. 7-1, page 63.

7.2 LMF-Board, SMPS (PSU), RFI Filter, and Fan

The LMF-Board, SMPS (PSU), RFI Filter, and Fan are located in the lower part of the Electronics Box, see Fig. 7-2, page 64.

Remove Top Cover.

Locate the lock bracket on the left side of the Electronics Box.

Loosen and remove the T10 lock screw located in the bracket.

Open up the Electronics Box.

Remove the clamp for the camera cable.

Remove the one T20 fixing screw for the EMC Ferrite (Lamp Cartridge cables).

Remove the three T20 fixing screws for the EMC connection bracket, see Fig. 7-1, page 63.

Remove the eighteen T10 fixing screws for the bottom cover plate.

Note the routing of the cables for later re-installation, see Fig. 7-1, page 63.

Pull the cables out of the cable clips / clamp.

Remove the bottom cover plate to get access to the boards and components.

Note: When closing the Electronics Box, be careful to arrange all cables correctly and make sure that no cables get jammed, see Fig. 7-1, page 63.

7.3 CBx-Board

Note: As a spare part, the Camera Board includes bottom part of EMC Cage, Mounting Plate and CCD, see Fig. 3-1, page 32.

Remove the Top Cover.

Remove the four fixing nuts for the CCD Mounting Plate.

The Camera Board (with EMC Cage and Mounting Plate) is now free to be removed.

Remove one fixing screw for lid of the EMC Cage.

Pull off the lid.

Remove the clamp for the flat cable brading.

Disconnect the camera cable.

After replacement of CBx-Board, do:

- CCD-Centering, Section 3.2.4, page 40.
- Vertical Positioning, Section 3.2.5, page 41.
- Check Scan-Width, if it is within the limits given in Section 3.2.3, page, 38.
- Focus will also be OK, and no further adjustments are required.
- Run Scanner Maintenance, Section 4.1.3, page 46.

These adjustments can be made without loosening the Camera Fixing Screws and without loosening the Focus Lock Screw.

7.4 Stepper Motor

Fig. 7-3, page 65.

Remove Electronics Box, see 6.3, page 55.

Loosen Belt Tightener.

For re-installation, see Fig. 7-4, Drive-Belt Tightener Adjustment, page 66.

Remove four T10 fixing screws.

Pull out Stepper Motor.

Move pulley from old motor to new motor.

7.5 Paper Entry Sensor

Fig. 7-5, page 67.

Remove Top Cover.

Locate the bracket for the Paper Entry Sensor.

Remove the two T10 fixing screws.

With a firm grip, pull and twist the bracket to pull out the Paper Entry Sensor (it may be necessary to force the sensor arm to flex a little to get the sensor out).

7.6 Paper Exit Sensor

Fig. 7-5, page 67.

Remove scanner chassis from Bottom Cover, see 6.4, page 55.

Locate the bracket for the Paper Exit Sensor.

Remove the two T10 fixing screws.

Pull out the Paper Exit Sensor.

7.7 Idler Rollers

Fig. 7-6, page 68.

Remove Scanner Chassis from Bottom Cover, see 6.4, page 55.

At left side of Scanner Chassis:

Remove Finger Guard (two M3 nuts) over the drive belt.

Remove the Guard for Gears (two T20 screws) over the pulley of the front Drive Roller.

Note: These two T20 screws also serve as fixing screws for the lamp reflector. To reinstall the Guard for Gears, guide the reflector bar by hand from below the reflector bar to align the holes of the bar with the holes of the side plate and the guard. See Fig. 7-7, page 69.

Rotate roller to get access to the set screws of the pulleys (leaving the belt on the pulleys).

Loosen the two T6 set screws in the pulley on the rear Idler Roller.

Loosen the two T6 set screws in the pulley on the front Drive Roller.

Pull off the Idle Roller Drive assembly.

Remove the Star Lock disc from the front Drive Roller.

Pull off the Bearing Bar.

At right side of the Scanner Chassis (motor side):

Remove the Extended Thickness Sensor.

Loosen the T6 set screws in the pulleys on the front and rear Idler Rollers (two screws in each pulley).

Pull off pulleys and drive belt.

Pull off Bearing Bar.

Remove Lid Link for Bearing Bar.

Lift up and pull out the Idler Rollers.

7.8 Drive Rollers

Fig. 7-6, page 68.

Remove Scanner Chassis from Bottom Cover, see 6.4, page 55.

Remove Paper Entry Sensor (the sensor arm bends slightly when the unit is pulled out).

Remove Paper Exit Sensor.

At left side of Scanner Chassis:

Remove Finger Guard (two M3 nuts) over the drive belt.

Remove the Guard for Gears (two T20 screws) over the pulley of the front Drive Roller.

Note: These two T20 screws also serve as fixing screws for the lamp reflector. To reinstall the Guard for Gears, guide the reflector bar by hand from below to align the holes of the reflector bar with the holes of the side plate and the guard. See Fig. 7-7, page 69.

Rotate the rollers to get access to the set screws of the pulleys.

Loosen the two T6 set screws in the pulley on the rear Drive Roller.

Loosen the two T6 set screws in the pulley on the front Drive Roller.

Pull off the Idler Roller Drive assembly.

Remove the Star Lock disc from the front Drive Roller.

Loosen the T6 set screw of the Tacho Disc.

Remove the bracket with Tacho Sensor and Disc.

Remove the Index Plunger and Bearing Plate from the front Drive Roller.

Remove the Bearing Plate for the rear Drive Roller.

At right side of Scanner Chassis (motor side):

Loosen the Belt Tightener.

For re-installation, see Fig. 7-4, Drive-Belt Tightener Adjustment, page 66.

Remove drive belt.

Loosen the T6 set screws in the pulleys on the front and rear Drive Rollers (two set screws in each).

Pull off the pulleys (mind the jointing tongues).

Remove the Index Plunger and Bearing Plate from the front Drive Roller.

Remove the Bearing Plate for the rear Drive Roller.

Pull out the Drive Rollers.

7.9 Lamp Cartridge, LCAA

In the HA68A scanners the lamp tube has been replaced by a Lamp Cartridge, which consists of a lamp tube and a light sensor.

Each Lamp Cartridge is factory calibrated, which means that the Lamp Cartridge can be replaced without the need for adjustment.

IMPORTANT: Do not attempt to disassemble the Lamp Cartridge in order to replace the lamp. This will ruin the calibration resulting in either reduced scanning quality or reduced lamp life.



WARNING:

Attempt to replace the lamp tube will violate safety and constitute a risk of electric shock, or injury to person

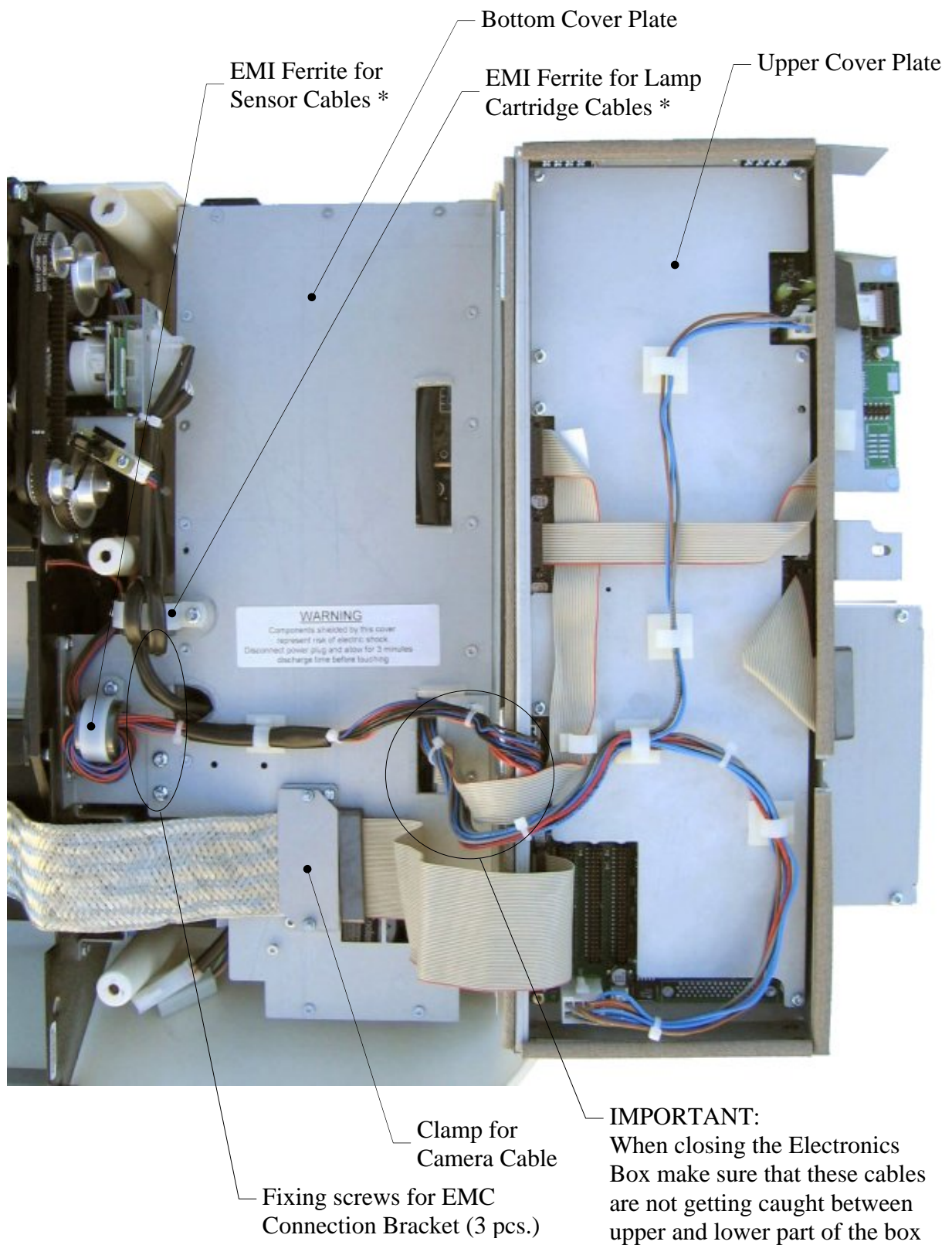

* Make sure that ferrites are properly closed

Fig. 7-1, Cable Routing

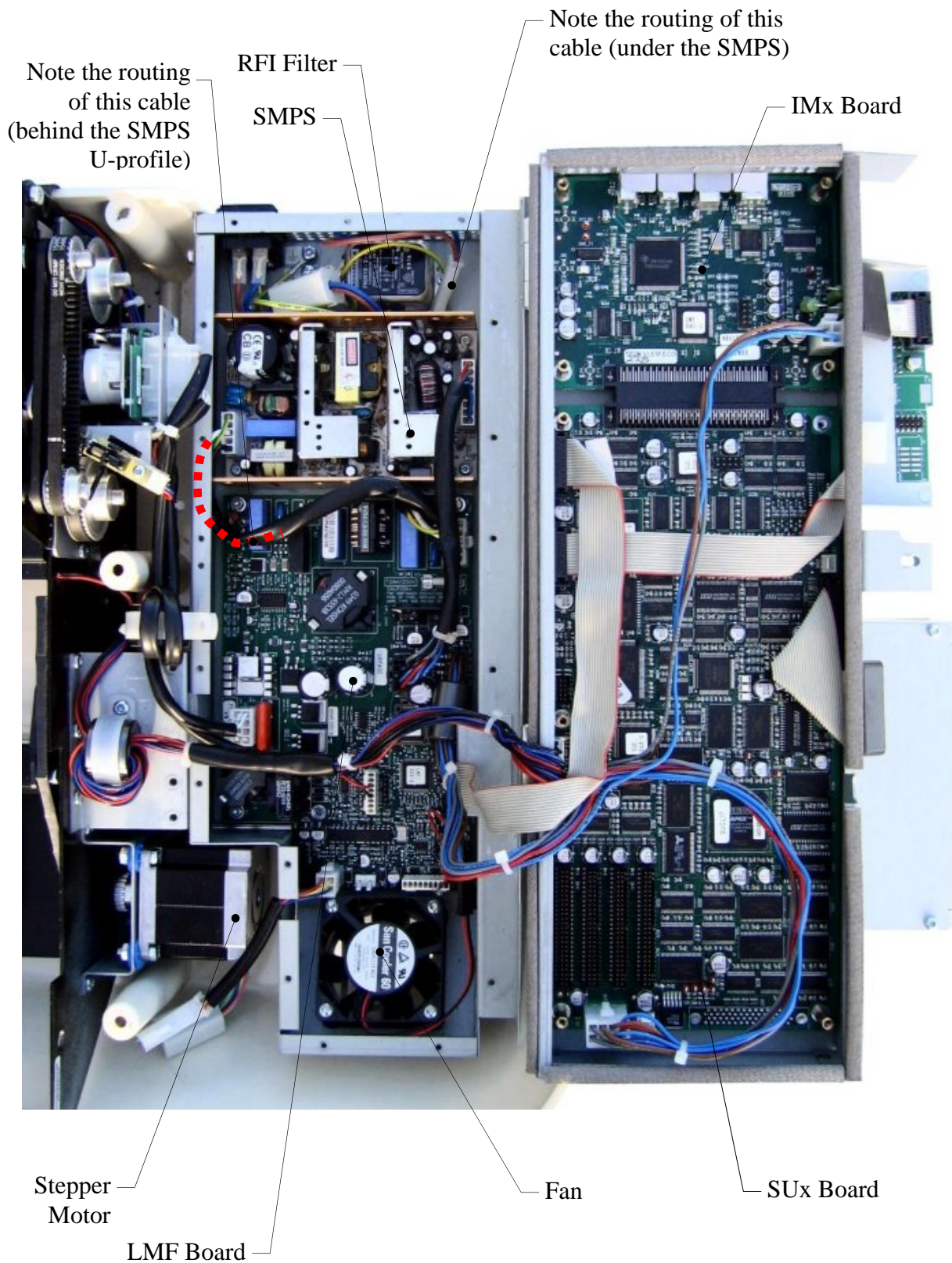

Fig. 7-2, Inside Electronics Box

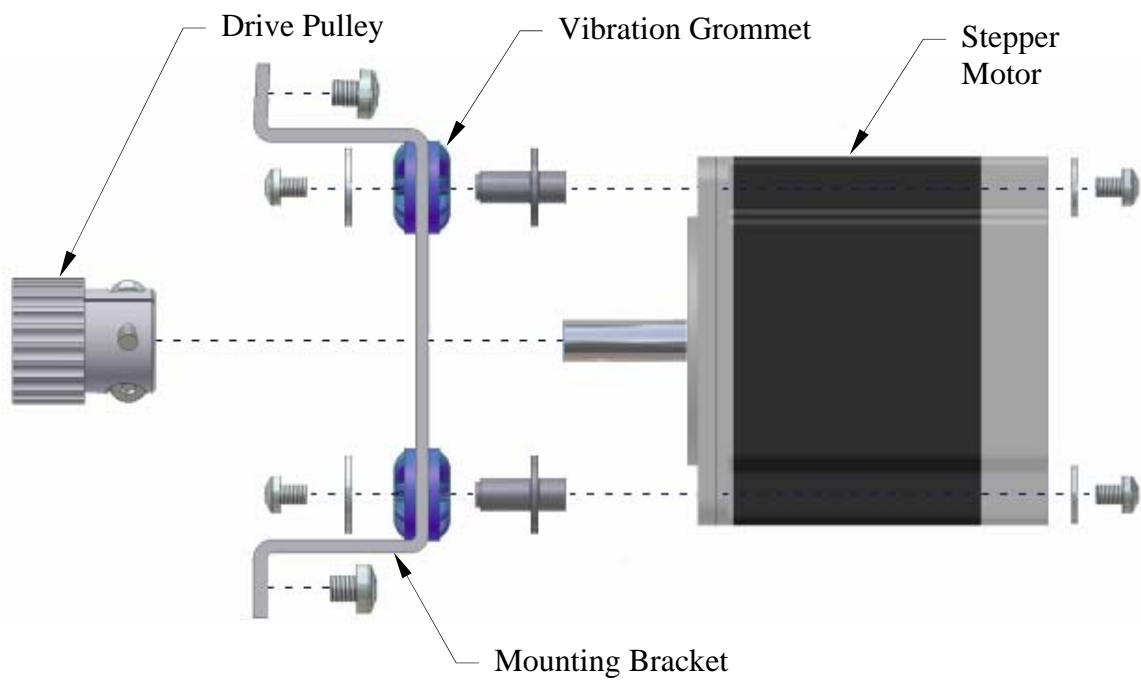

Fig. 7-3, Stepper Motor

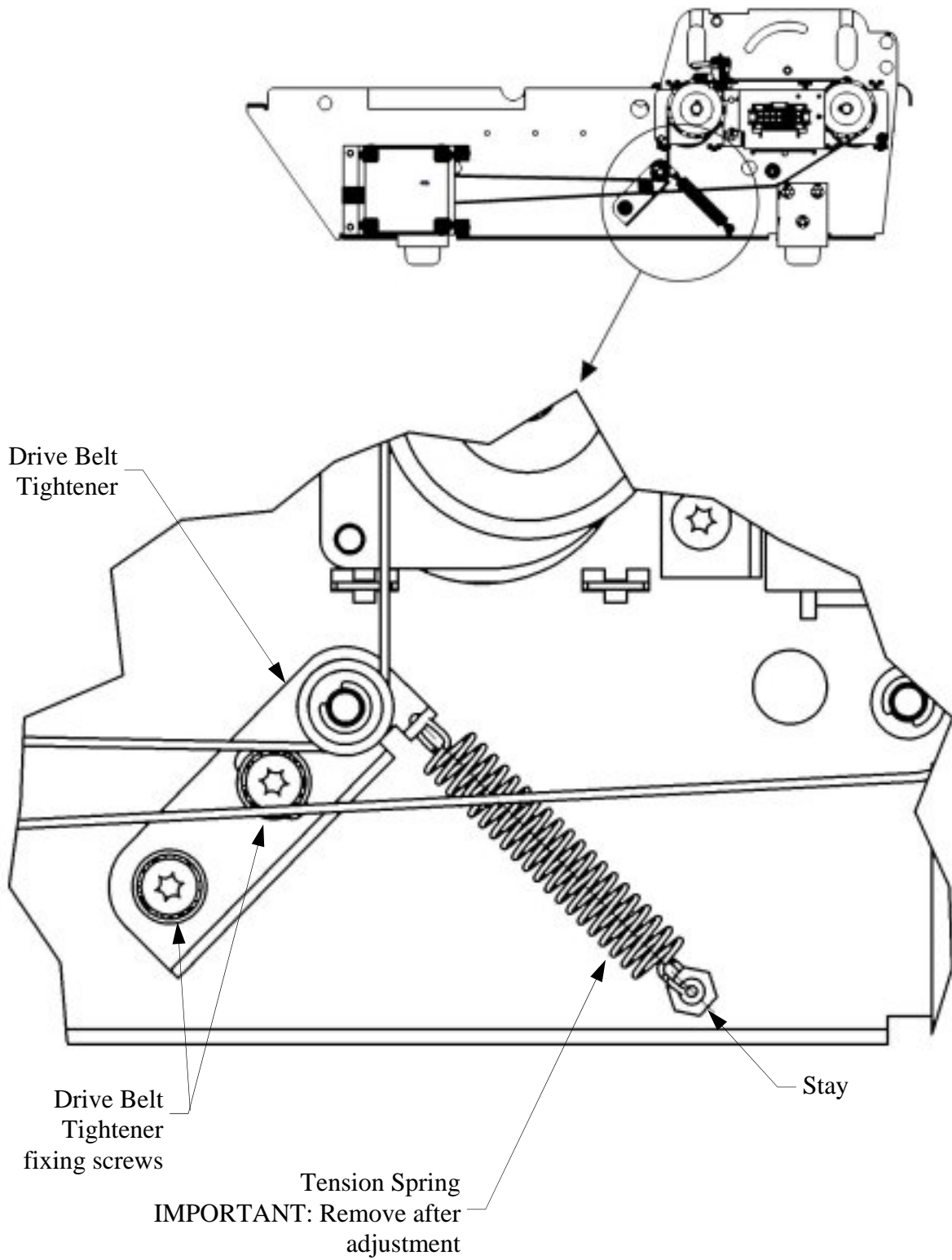

Fig. 7-4, Drive-Belt Tightener Adjustment

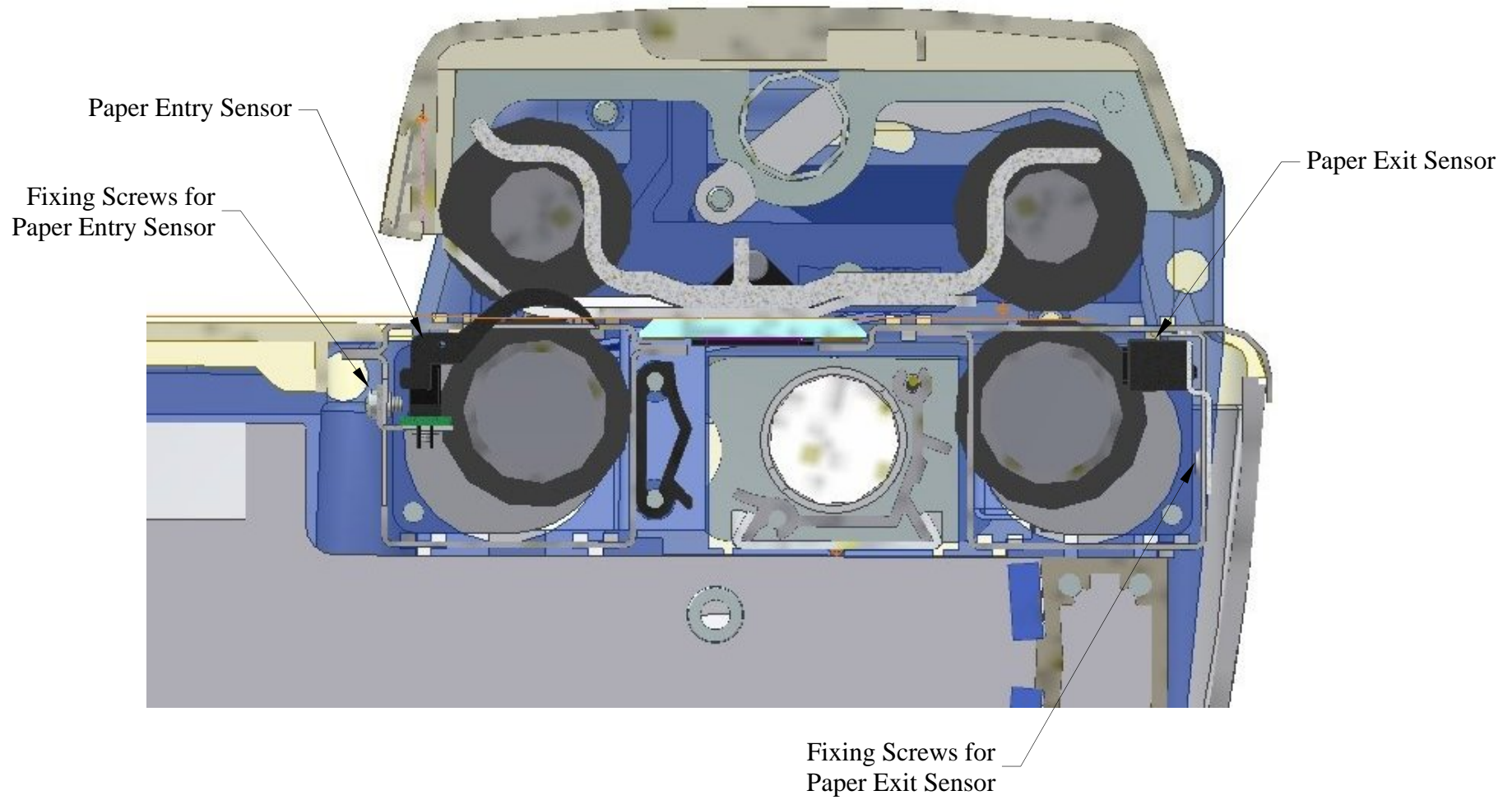

Fig. 7-5, Paper Sensors

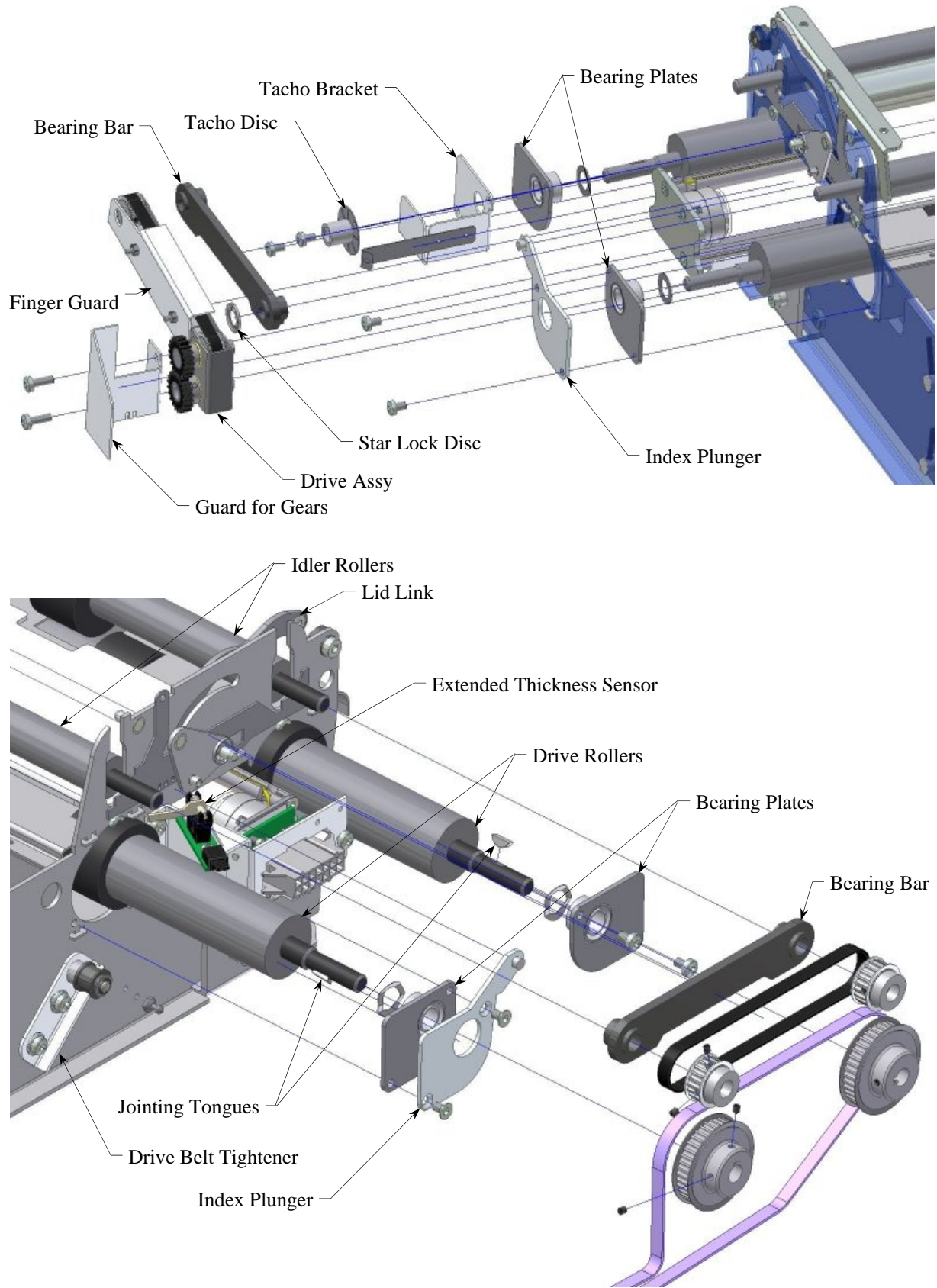

Fig. 7-6, Drive System

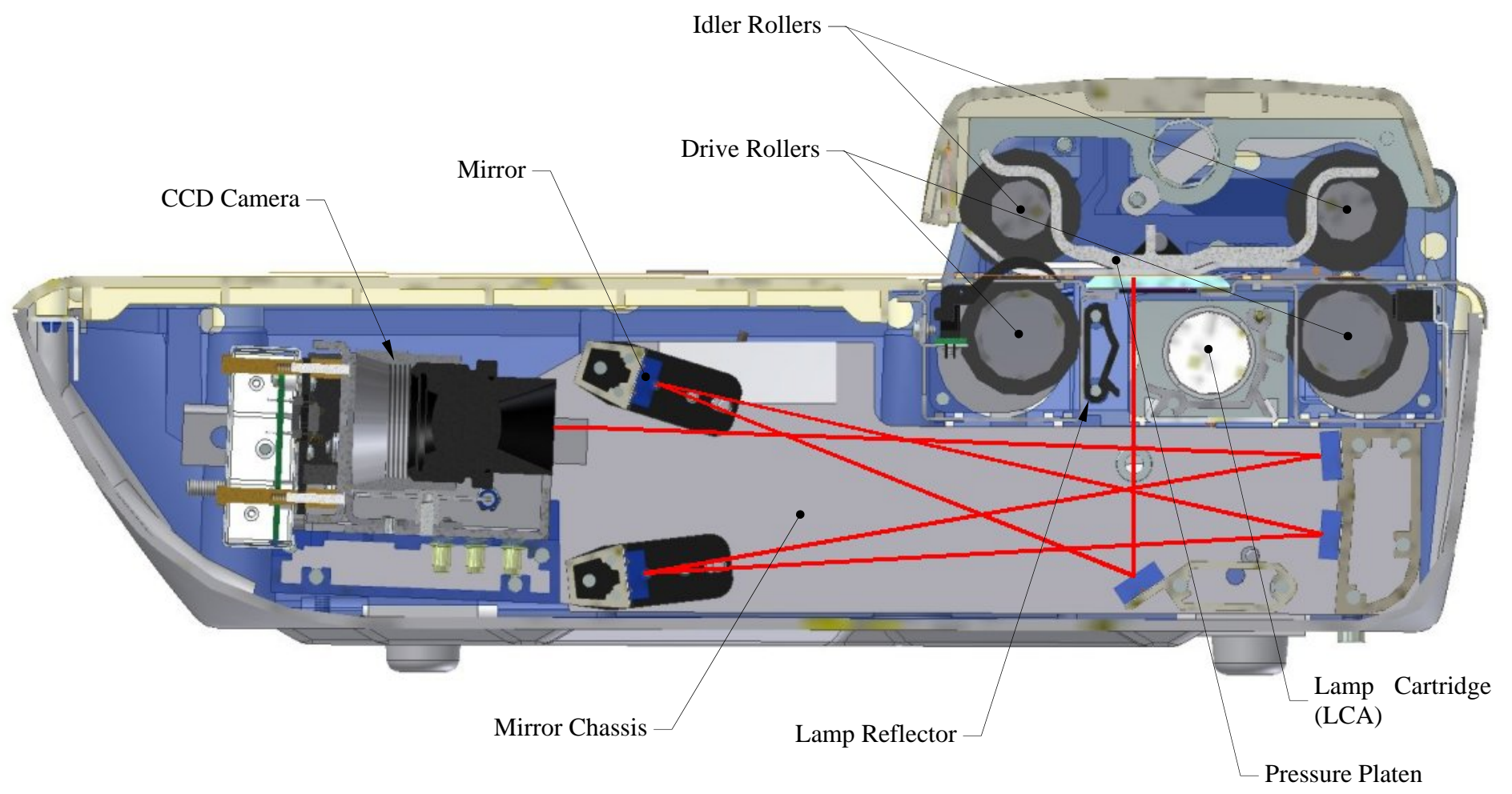

Fig. 7-7, Scanner Cross Section

8. SCANtest

The purpose of the scanner test program, SCANtest, is to support troubleshooting and adjustment of the scanners.

When SCANtest has been started, the scanner is switched into Test Mode, and the Diagnostic LED Indicator on the Operator Panel is turned ON.

Scanner Test Program Menu

Test 1:	Scanner Information
Test 2:	LED Test
Test 3:	Key Test
Test 4:	Original-Sensor Test
Test 5:	Lamp Test
Test 6:	Motor Test
Test 7:	Complete Hardware Test
Test 9:	Camera Adjustment
Test 12:	Adjust Y-Axis Scaling
Test 13:	Switch Scanner to Test Mode
Test 20:	Noise Test
Test 21:	Scan Dump

If SCANtest is started when the scanner is in Error Mode, the Error Code Number and a short description of the error will be displayed on the screen.

8.1 Description of SCANtest

8.1.1 Test 1, Scanner Information

Purpose: To display scanner data and to enter or change the serial number of the scanner. The serial number is stored in Flash memory on the SUx-Board.

The following is displayed:

Scanner Model:
 Firmware Release:
 Firmware Release Date:
 Firmware Build:
 FPGA Revision:
 FPGA Release Date:
 Boot Code Revision:
 Boot Code Release Date:
 Scanner ID Switch:
 SCSI ID:
 Serial Number:
 Lamp Light On: *)

*) Password for reset of counter is “xetnoc”

8.1.2 Test 2, LED Test

Purpose: To test the LED Indicators on the Operator Panel.

Description:

All LEDs are sequentially switched ON/OFF until Test 2 is terminated.

8.1.3 Test 3, Key Test

Purpose: To test the Keys on the Operator Panel.

Description

Each key on the Operator Panel will turn a LED ON when pressed.

Key	LED
Forward and Reverse	Ready (Green)
Appl. (E-mail, Scan, and Copy)	Wait
Power	Wait

8.1.4 Test 4, Original-Sensor Test

Purpose: To test the Original Sensors and the Extended Thickness Detector.

Description:

The following LEDs turn ON when one of the Original-Sensors is activated:

Actuator	LED
Original Entry Sensor	Ready (Green)
Original Exit Sensor	Ready (Green)
Media Thickness Sensor *)	Wait

*) Start SCANtest, Test 4

Set Thickness Adjustment Sliders to pos. 6 (second step).
Close Lid to lower the Idler Rollers.
Check that the WAIT LED remains ON.
Set Thickness Adjustment Sliders to pos. 3 (first step).
Close Lid to lower the Idler Rollers.
Check that the spacing between the Idler and Drive rollers is at least 1 mm when the WAIT LED turns OFF.

8.1.5 Test 5, Lamp Test

Purpose: To test the Lamp and associated electronics.

Description: A message on the screen will inform whether the **Lamp** is turned ON or OFF (Lamp power is turned ON/OFF) and whether the **Light** is ON/OFF (Light is detected or not). The Lamp is delayed approx. 2 seconds when switched ON.

8.1.6 Test 6, Motor Test

Purpose: To test the Stepper Motor and associated electronics.

Description: From the menu the motor speed and the direction of rotation can be selected.

8.1.7 Test 7, Complete Hardware Test

Purpose: To test various functions on the SUx and CBx -Boards.

8.1.8 Test 9, Camera Adjustment

Purpose: To support CCD Camera evaluation and adjustments.

Description: Test 9 contains a “Software Oscilloscope” for check and adjustment of the cameras. The following functions can be selected from the Test Program Menu.

- Uncorrected or Corrected Light Profile
- Red, Green, Blue, or Gray Color Channel (Selections depend on scanner model)
- Special Detail Views for Light Profile, Scan Width, and Vertical Positioning
- Save screen images
- Print screen images
- Load saved images

The contents of Detail Views is marked on the upper overview window by red vertical lines. The continuous lines refer to the left Detail View and the dashed lines to the right Detail View.

8.1.9 Test 12, Adjustment of Y-Axis Scaling

Purpose: To adjust the Y-Axis Scaling.

Description: The scaling (dpi) in the mechanical scan direction (Y-Axis) depends on the speed of the stepper motor relative to the scanline Exposure Time. The default motor speed can be changed $\pm 1\%$, either from Test 12 or by using the ‘Scanner Setup/Correction factor ...’ option of WIDEimage.

The correction factor is stored in the Flash Memory on the SUx-Board.

8.1.10 Test 13, Switch Scanner to Test Mode

Purpose: To switch the scanner back to Test Mode. Useful if the scanner gets out of Test Mode, e.g. if it has to be turned OFF/ON during troubleshooting.

8.1.11 Test 20, Noise Test

Purpose: To detect and locate the possible cause (dust, dirt, scratches,..) of vertical lines running from top to bottom of the scanned image.

Description: Test 20 scans the White Calibration Area of the SM Calibration Sheet and displays, for each color channel, the graytone values of each separate pixel averaged over the scanned band. The displayed image of the SM Calibration Sheet will be superimposed by low level noise caused by the CCD chip, and larger spikes most likely caused by dust, dirt, scratches, or similar defects on the Glass Plate. In rare cases, larger spikes may be caused by dust, dirt, or pixel faults on the CCD chip.

The positions of larger spikes are shown by the numbers (cm or inch units) opposite to the spikes. The numbers refer to the distance measured from the left side of the scan-area.

Larger spikes going downwards are often caused by dust, dirt, scratches, or similar defects on the Glass Plate and may be removed by cleaning the Glass Plate.

Downward spikes often show up as darker vertical lines in the scanned image, see Fig. 8-1, page 74.

Larger spikes going upwards are often caused by dust or dirt present on the Glass Plate during the last calibration with Scanner Maintenance. These defects are memorized by the Light Profiles stored in Flash Memory and can only be removed by cleaning of the Glass Plate followed by running Scanner Maintenance again.

Upward spikes show up as very bright vertical lines in the scanned image, see Fig. 8-1, page 74.

White vertical lines in the scanned image may be found even if Noise Test shows a perfectly 'clean' scanner. In this case, the cause may be white dust or particles on the backside of the Glass Plate having the same color as the white background.

In this case, the Light Profiles of SCANtest, Test 9 may show upwards going spikes when a dark original is placed in the scan-area.

8.1.12 Test 21, SCANDump

Purpose: To create a file, SCANDump.con, which contains Light Profiles and other scanner data for diagnostics purposes.

Description: The file SCANDump.con will be placed in the directory pointed to by the SET TEMP environment variable.

The files contained in SCANDump.con may be unpacked by SCANview by double clicking on SCANDump.con.

The unpacked Light Profiles may be viewed by SCANview. If other files are included use an appropriate reader or viewer.

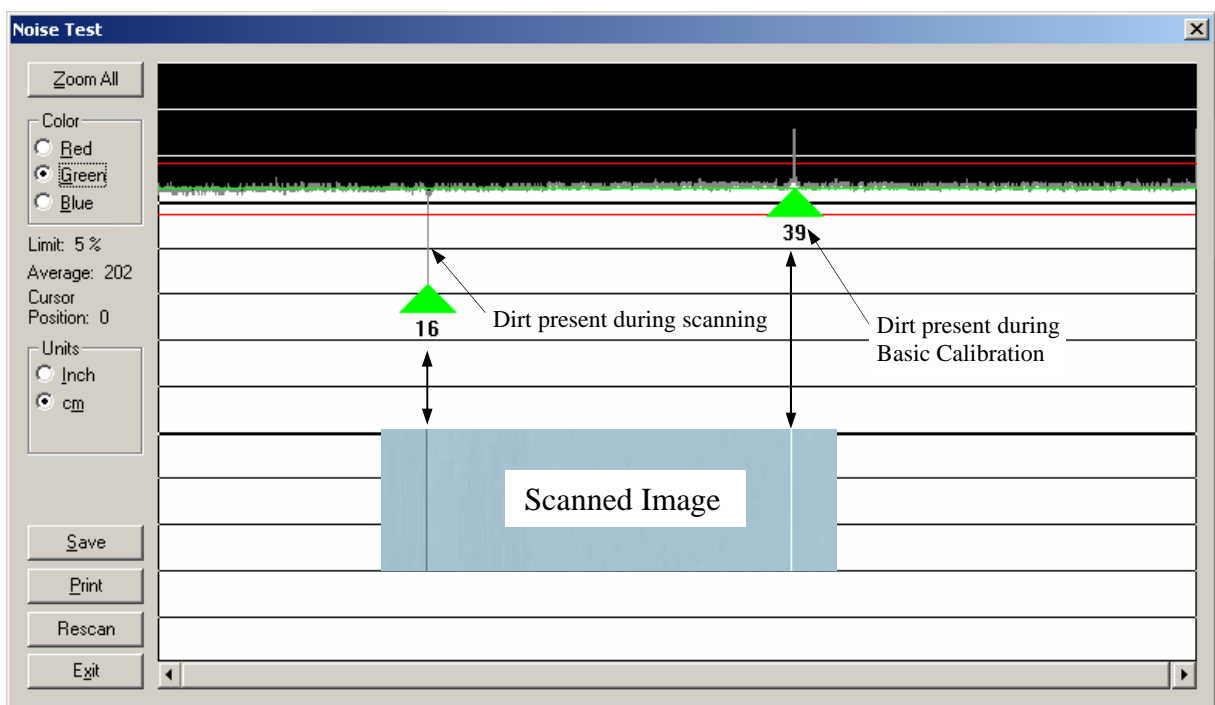

Fig. 8-1, Noise Test, Example

9. Wiring Diagram

Fig. 9-1, Hx68A Wiring Diagram page 76

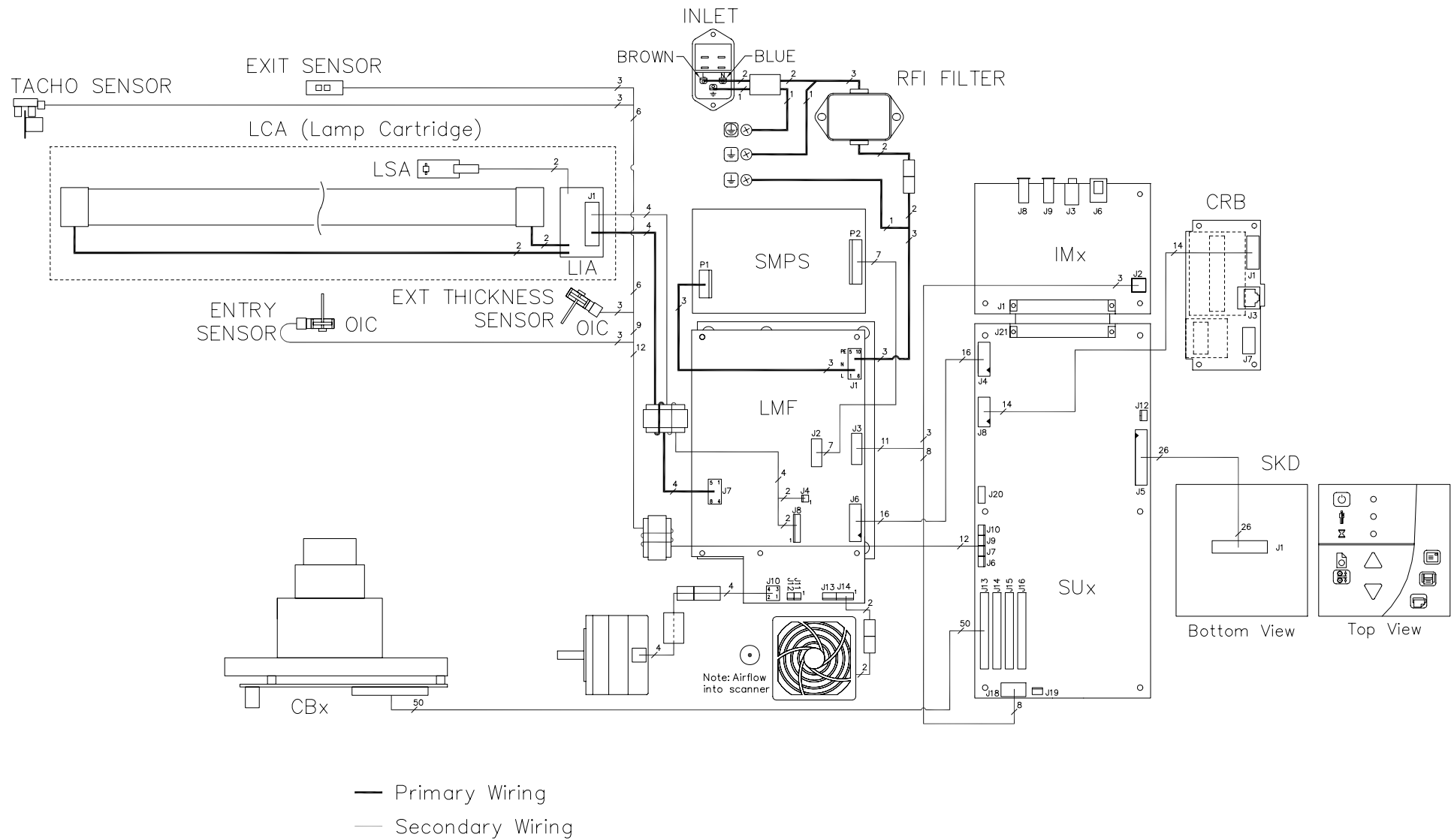

Fig. 9-1, Hx68A Wiring Diagram

10. Special Service Tools

Adjustment and Test Patterns:

Scanner Model:	HA68A	HB68A
Optical Adjustment Pattern, 36", 1 Cam. p/n 6879A107R01	×	×
Focus Pattern, 40" p/n 6779D216R01	×	×
SM Calibration Sheet, 42" p/n 6799D171	×	×

Special Tools:

Scanner Model:	HA68A	HB68A
Adjustment Spring for Belt Tension	6775A252	6775A252
Key for Camera Adjustment (Torx 20)	0008V354	0008V354

For cleaning of the Glass Plate and the Pressure Platen use:

- Ordinary window-cleaning detergent
- Soft lint-free cloth
- Microfibre Cleaning Cloth (as the cloth supplied with scanner)

For cleaning of the CCD use:

A soft lint-free cloth and ethyl alcohol be careful not to scratch the glass.

11. Appendix A, Error Codes

As we continuously try to improve the error system, error codes and/or corrective actions may differ from the list below. You can get the latest error list by typing **WS /errorlist** from a command prompt in the WIDeSystem install folder (C:\Program Files\Contex\WIDeSystem) or find the latest error lists on the support home page.

Please note that not all errors may apply to the actual scanner.

Error List

WIDeSystemApplication 3.4, Build 03233.

Wed May 03 15:39:15 2006

Legend

(U) = UserCorrectable

(S) = Support Correctable

(R) = R&D Correctable

(W) = Warnings

Error Code	Corrective Action	Description
Scanner API (ctx_scan_2000)		
51-1	(U)	Incorrect scanner status. Please check the paper path and reload the media.
51-2	(R)	Check Sense Info
51-3	(R)	Unknown ASPI error
51-4	(R)	Unexpected number of byte received from scanner
51-5	(R)	ASPI call never completed
51-6	(R)	WaitForObject failed
51-7	(R)	ASPI abandoned
51-8	(R)	It was not possible to allocate a sync object
51-9	(R)	It was not possible to get/set the timeout inside the ASPI driver
51-10	(R)	Parameter error in CTX_SCAN call
51-11	(R)	CTX_SCAN could not find a SCSI interface board
51-12	(U)	The driver for the scanner can not be found. Please reinstall the software to correct the issue.
51-13	(R)	A SCSI protocol error was detected
51-14	(R)	An operating system error was detected
51-15	(R)	The IO command has not yet completed
51-16	(R)	An internal CTX_xxx driver error occurred
51-17	(R)	The driver specified was too old
51-18	(U)	No supported scanner was found. Please verify that your scanner is properly connected, and then retry the operation.
51-19	(U)	The driver for the scanner can not be found. Please reinstall the software to correct the issue.
51-20	(R)	It was not possible to close the library, because a scanner is not closed
51-21	(R)	The calling program tried to open an already open scanner
51-22	(R)	The calling program tried to do I/O on a closed scanner
51-23	(R)	The calling program tried to close an already closed scanner
51-24	(R)	The calling program tried to open an unknown handle
51-25	(R)	The STI thread failed to return within 30 secs

Error Code	Corrective Action	Description
51-26	(U)	Internal command error in driver. Please restart application or system.
51-27	(U)	Windows failed to lock STI/WIA device. Please reboot your system.
51-28	(U)	Windows failed to unlock STI/WIA device. Please reboot your system.
51-29	(U)	The connection to the scanner have been lost. Please restart the application.
51-30	(U)	Unable to find scanner. Please check cabling between scanner and PC and restart the application. Alternatively restart your system.
51-31	(U)	The scanner is currently reserved by another application or user. Please wait for the reservation to expire.
51-32	(U)	The operation was aborted due to an internal Windows Error. Please restart the application.
WIDEsystem (WS)		
57-1	(U)	Unable to read the timer settings in the scanner. Please remove any loaded media from the scanner, and switch back and forth between this tab and another tab.
57-2	(R)	Cannot read timer settings.
57-3	(U)	The current timer values stored in the scanner are invalid. Please select new values and press the Apply button.
57-4	(U)	The On time must be before the Off time. Please make a new selection.
57-5	(R)	Scanner timer write operation failed.
57-6	(R)	Scanner timer read operation failed.
57-7	(R)	Scanner timer write operation failed.
57-8	(R)	The scanner does not support software controlled powering up/down.
57-9	(U)	Unable to read the time from the scanner. Please remove any loaded media from the scanner.
57-10	(U)	Unable to write the time to the scanner. Please remove any loaded media from the scanner.
57-11	(U)	ASPI must be installed for %s to work on NT
57-12	(U)	The driver for the scanner can not be found. Please reinstall the software to correct the issue.
57-13	(W)	The language file is not the correct version. Please reinstall the software to correct the issue.
Scanner		
100-118	(U)	Unable to communicate with the scanner. Please check the connection to the scanner.
		Troubleshooting sequence:
		1. User interaction.
		2. PC (cable, PC hardware/software etc.)
		3. Interface board (IMx).
100-119	(R)	Invalid SCSI command
		Troubleshooting sequence:
		1. PC (cable, PC hardware/software etc.)
		2. Firmware.
100-120	(R)	Invalid value in SCSI CDB
		Troubleshooting sequence:
		1. PC (cable, PC hardware/software etc.)
		2. Firmware.
100-121	(R)	Invalid SCSI parameter list length
		Troubleshooting sequence:

Error Code	Corrective Action	Description
		1. PC (cable, PC hardware/software etc.)
		2. Firmware.
100-122	(R)	Invalid SCSI parameter field
		Troubleshooting sequence:
		1. PC (cable, PC hardware/software etc.)
		2. Firmware.
100-123	(R)	Unsupported SCSI parameter
		Troubleshooting sequence:
		1. PC (cable, PC hardware/software etc.)
		2. Firmware.
100-124	(R)	Invalid SCSI parameter value
		Troubleshooting sequence:
		1. PC (cable, PC hardware/software etc.)
		2. Firmware.
100-125	(U)	Incorrect scanner status. Please check the paper path and reload the media.
		Troubleshooting sequence:
		1. PC (cable, PC hardware/software etc.)
		2. Firmware.
100-126	(R)	SCSI time-out
		Troubleshooting sequence:
		1. PC (cable, PC hardware/software etc.)
		2. Firmware.
100-127	(U)	The scanner keyboard was used during communication with the scanner.
		Troubleshooting sequence:
		1. User interaction.
100-128	(U)	The scanner has paper jam. Please reload the media.
		Troubleshooting sequence:
		1. User interaction.
		2. Related mechanical parts.
		3. Lamp and Motor driver board (LMx)
		4. Switch Mode Power Supply (SMPS)
		5. Main controller board (SUx).
100-129	(U)	The scanner does not support this test command in normal mode. Please restart test program.
		Troubleshooting sequence:
		1. User interaction.
100-130	(U)	The scanner does not support this command in test mode. Please turn off the scanner, and turn it on again.
		Troubleshooting sequence:
		1. User interaction.
100-131	(U)	The scanner is initializing. Please retry the operation when the scanner has finished initializing.
		Troubleshooting sequence:
		1. User interaction.
100-132	(U)	The scanner is warming up. Please retry the operation when the scanner has finished warming up.
		Troubleshooting sequence:

Error Code	Corrective Action	Description
		1. User interaction.
100-133	(U)	The scanner cannot reverse the media while the paper guide is in extended position. Please reload the media manually.
		Troubleshooting sequence:
		1. User interaction.
100-134	(U)	The scanner is calibrating. Please retry the operation when the scanner has finished calibrating.
		Troubleshooting sequence:
		1. User interaction.
100-135	(R)	Invalid firmware CRC
		Troubleshooting sequence:
		1. User interaction.
		2. Main controller board (SUx).
100-136	(U)	The scanner is on standby. Please turn on the scanner and retry the operation when the scanner is ready.
		Troubleshooting sequence:
		1. User interaction.
100-137	(R)	Invalid identify message
		Troubleshooting sequence:
		1. Firmware.
100-138	(R)	Logical unit not supported
		Troubleshooting sequence:
		1. PC (cable, PC hardware/software etc.)
		2. Firmware.
100-139	(R)	PROCESSOR EXCEPTION 0, divide by zero
		Troubleshooting sequence:
		1. Firmware.
100-140	(R)	PROCESSOR EXCEPTION 1, debug
		Troubleshooting sequence:
		1. Firmware.
100-141	(R)	PROCESSOR EXCEPTION 2, non-maskable interrupt
		Troubleshooting sequence:
		1. Firmware.
100-142	(R)	PROCESSOR EXCEPTION 3, break point
		Troubleshooting sequence:
		1. Firmware.
100-143	(R)	PROCESSOR EXCEPTION 4, overflow
		Troubleshooting sequence:
		1. Firmware.
100-144	(R)	PROCESSOR EXCEPTION 5, bound
		Troubleshooting sequence:
		1. Firmware.
100-145	(R)	PROCESSOR EXCEPTION 6, invalid opcode
		Troubleshooting sequence:
		1. Firmware.
100-146	(R)	PROCESSOR EXCEPTION 7, device not available
		Troubleshooting sequence:

Error Code	Corrective Action	Description
		1. Firmware.
100-147	(R)	PROCESSOR EXCEPTION 8, double fault
		Troubleshooting sequence:
		1. Firmware.
100-148	(R)	PROCESSOR EXCEPTION 9, coprocessor segment overrun
		Troubleshooting sequence:
		1. Firmware.
100-149	(R)	PROCESSOR EXCEPTION 10, invalid TSS
		Troubleshooting sequence:
		1. Firmware.
100-150	(R)	PROCESSOR EXCEPTION 11, segment not present
		Troubleshooting sequence:
		1. Firmware.
100-151	(R)	PROCESSOR EXCEPTION 12, stack fault
		Troubleshooting sequence:
		1. Firmware.
100-152	(R)	PROCESSOR EXCEPTION 13, protection fault
		Troubleshooting sequence:
		1. Firmware.
100-153	(R)	PROCESSOR EXCEPTION 14, page fault
		Troubleshooting sequence:
		1. Firmware.
100-214	(U)	The scanner's smart card is either invalid or missing. Check that the smart card has been correctly inserted into the card slot, and that it is a valid type for the scanner.
		Troubleshooting sequence:
		1. User interaction.
		2. Smart Card Reader board (CRx).
		3. Main controller board (SUx).
		4. Related cabling.
100-1000	(R)	No sense information
100-1001	(U)	Please insert media in the scanner.
		Troubleshooting sequence:
		1. User interaction.
100-1002	(U)	Please reload the media.
		Troubleshooting sequence:
		1. User interaction.
100-1003	(U)	The scanner operation was interrupted by a user.
		Troubleshooting sequence:
		1. User interaction.
100-1004	(U)	Media is currently being loaded by the scanner. Please retry the operation when the media has been loaded.
		Troubleshooting sequence:
		1. User interaction.
100-1005	(U)	Media is currently being positioned by the scanner. Please retry the operation when the media has been positioned.
		Troubleshooting sequence:
		1. User interaction.

Error Code	Corrective Action	Description
100-1006	(U)	The scanner has paper jam. Please reload the media.
		Troubleshooting sequence:
		1. User interaction.
100-1007	(U)	The scanner cannot reverse the media while the paper guide is in extended position. Please reload the media manually.
		Troubleshooting sequence:
		1. User interaction.
100-1008	(U)	The scanner is calibrating. Please retry the operation when the scanner has finished calibrating.
		Troubleshooting sequence:
		1. User interaction.
100-1009	(U)	The scanner's reject bin is either full or closed. Please inspect it before retrying the operation.
		Troubleshooting sequence:
		1. User interaction.
100-1010	(R)	Read past end of medium
		Troubleshooting sequence:
		1. User interaction.
100-1011	(R)	Read past beginning of medium
		Troubleshooting sequence:
		1. User interaction.
100-2000	(U)	The scanner is powering up. Please wait until the scanner is ready and retry the operation.
		Troubleshooting sequence:
		1. User interaction.
100-2001	(U)	Incorrect scanner status. Please check the paper path and reload the media.
		Troubleshooting sequence:
		1. User interaction.
100-2002	(U)	The scanner does not support this test command in normal mode. Please restart test program.
		Troubleshooting sequence:
		1. User interaction.
100-2003	(U)	The scanner does not support this command in test mode. Please turn off the scanner, and turn it on again.
		Troubleshooting sequence:
		1. User interaction.
100-2004	(R)	Read past end of tile
100-2005	(R)	Time-out on request
		Troubleshooting sequence:
		1. PC (cable, PC hardware/software etc.)
		2. Firmware.
100-2006	(R)	SOEM time-out
100-2007	(R)	No active PCEPC mode
100-2008	(R)	Error in PCEPC communication
100-2009	(R)	Fatal error in OS
		Troubleshooting sequence:
		1. Firmware.
100-2010	(R)	Fatal error in SCSI-system

Error Code	Corrective Action	Description
100-2011	(R)	Fatal Error in firmware
		Troubleshooting sequence:
		1. Firmware.
100-2012	(U)	The scanner's smart card is either invalid or missing. Check that the smart card has been correctly inserted into the card slot, and that it is a valid type for the scanner.
		Troubleshooting sequence:
		1. User interaction.
100-2013	(U)	The scanner's smart card is not a valid type for this scanner. Please replace it with a valid card.
		Troubleshooting sequence:
		1. User interaction.
100-2014	(U)	The scanner is on standby. Please turn on the scanner and retry the operation when the scanner is ready.
		Troubleshooting sequence:
		1. User interaction.
100-2015	(U)	The scanner did not find any Hollerith data on the aperture card. Please check that the card is valid and correctly inserted.
		Troubleshooting sequence:
		1. User interaction.
100-2016	(U)	The scanner cover is open. Close it before retrying the operation.
		Troubleshooting sequence:
		1. User interaction.
100-3000	(U)	The firmware was not downloaded properly. Please try to download the firmware again.
		Troubleshooting sequence:
		1. User interaction.
		2. Main controller board (SUx).
100-3001	(U)	Unknown firmware error
		Troubleshooting sequence:
		1. User interaction.
100-3002	(U)	Unable to adjust camera A up. Please clean the white background and the glass plate. Then run your maintenance software.
		Troubleshooting sequence:
		1. User interaction.
100-3003	(U)	Unable to adjust camera B up. Please clean the white background and the glass plate. Then run your maintenance software.
		Troubleshooting sequence:
		1. User interaction.
100-3004	(U)	Unable to adjust camera C up. Please clean the white background and the glass plate. Then run your maintenance software.
		Troubleshooting sequence:
		1. User interaction.
100-3005	(U)	Unable to adjust camera D up. Please clean the white background and the glass plate. Then run your maintenance software.
		Troubleshooting sequence:
		1. User interaction.
100-3006	(U)	Unable to adjust camera E up. Please clean the white background and the glass plate. Then run your maintenance software.

Error Code	Corrective Action	Description
		Troubleshooting sequence:
		1. User interaction.
100-3007	(U)	Unable to adjust camera F up. Please clean the white background and the glass plate. Then run your maintenance software.
		Troubleshooting sequence:
		1. User interaction.
100-3008	(U)	Unable to adjust camera A down. Please clean the white background and the glass plate. Then run your maintenance software.
		Troubleshooting sequence:
		1. User interaction.
100-3009	(U)	Unable to adjust camera B down. Please clean the white background and the glass plate. Then run your maintenance software.
		Troubleshooting sequence:
		1. User interaction.
100-3010	(U)	Unable to adjust camera C down. Please clean the white background and the glass plate. Then run your maintenance software.
		Troubleshooting sequence:
		1. User interaction.
100-3011	(U)	Unable to adjust camera D down. Please clean the white background and the glass plate. Then run your maintenance software.
		Troubleshooting sequence:
		1. User interaction.
100-3012	(U)	Unable to adjust camera E down. Please clean the white background and the glass plate. Then run your maintenance software.
		Troubleshooting sequence:
		1. User interaction.
100-3013	(U)	Unable to adjust camera F down. Please clean the white background and the glass plate. Then run your maintenance software.
		Troubleshooting sequence:
		1. User interaction.
100-3014	(U)	Unable to stitch cameras A and B. Please clean the white background and the glass plate. Then run your maintenance software.
		Troubleshooting sequence:
		1. User interaction.
100-3015	(U)	Unable to stitch cameras B and C. Please clean the white background and the glass plate. Then run your maintenance software.
		Troubleshooting sequence:
		1. User interaction.
100-3016	(U)	Unable to stitch cameras C and D. Please clean the white background and the glass plate. Then run your maintenance software.
		Troubleshooting sequence:
		1. User interaction.
100-3017	(U)	Unable to stitch cameras D and E. Please clean the white background and the glass plate. Then run your maintenance software.
		Troubleshooting sequence:
		1. User interaction.
100-3018	(U)	Unable to stitch cameras E and F. Please clean the white background and the glass plate. Then run your maintenance software.
		Troubleshooting sequence:

Error Code	Corrective Action	Description
		1. User interaction.
100-3019	(U)	Error calibrating. Please clean the white background and the glass plate. Then run your maintenance software.
		Troubleshooting sequence:
		1. User interaction.
100-3020	(U)	Error calibrating camera A, red. Please clean the white background and the glass plate. Then run your maintenance software.
		Troubleshooting sequence:
		1. User interaction.
100-3021	(U)	Error calibrating camera A, green. Please clean the white background and the glass plate. Then run your maintenance software.
		Troubleshooting sequence:
		1. User interaction.
100-3022	(U)	Error calibrating camera A, blue. Please clean the white background and the glass plate. Then run your maintenance software.
		Troubleshooting sequence:
		1. User interaction.
100-3023	(U)	Error calibrating camera B, red. Please clean the white background and the glass plate. Then run your maintenance software.
		Troubleshooting sequence:
		1. User interaction.
100-3024	(U)	Error calibrating camera B, green. Please clean the white background and the glass plate. Then run your maintenance software.
		Troubleshooting sequence:
		1. User interaction.
100-3025	(U)	Error calibrating camera B, blue. Please clean the white background and the glass plate. Then run your maintenance software.
		Troubleshooting sequence:
		1. User interaction.
100-3026	(U)	Error calibrating camera C, red. Please clean the white background and the glass plate. Then run your maintenance software.
		Troubleshooting sequence:
		1. User interaction.
100-3027	(U)	Error calibrating camera C, green. Please clean the white background and the glass plate. Then run your maintenance software.
		Troubleshooting sequence:
		1. User interaction.
100-3028	(U)	Error calibrating camera C, blue. Please clean the white background and the glass plate. Then run your maintenance software.
		Troubleshooting sequence:
		1. User interaction.
100-3029	(U)	Error calibrating camera D, red. Please clean the white background and the glass plate. Then run your maintenance software.
		Troubleshooting sequence:
		1. User interaction.
100-3030	(U)	Error calibrating camera D, green. Please clean the white background and the glass plate. Then run your maintenance software.
		Troubleshooting sequence:
		1. User interaction.

Error Code	Corrective Action	Description
100-3031	(U)	Error calibrating camera D, blue. Please clean the white background and the glass plate. Then run your maintenance software.
		Troubleshooting sequence:
		1. User interaction.
100-3032	(U)	Error calibrating camera E, red. Please clean the white background and the glass plate. Then run your maintenance software.
		Troubleshooting sequence:
		1. User interaction.
100-3033	(U)	Error calibrating camera E, green. Please clean the white background and the glass plate. Then run your maintenance software.
		Troubleshooting sequence:
		1. User interaction.
100-3034	(U)	Error calibrating camera E, blue. Please clean the white background and the glass plate. Then run your maintenance software.
		Troubleshooting sequence:
		1. User interaction.
100-3035	(U)	Error calibrating camera F, red. Please clean the white background and the glass plate. Then run your maintenance software.
		Troubleshooting sequence:
		1. User interaction.
100-3036	(U)	Error calibrating camera F, green. Please clean the white background and the glass plate. Then run your maintenance software.
		Troubleshooting sequence:
		1. User interaction.
100-3037	(U)	Error calibrating camera F, blue. Please clean the white background and the glass plate. Then run your maintenance software.
		Troubleshooting sequence:
		1. User interaction.
100-3038	(R)	Error programming multiplier FLASH
100-3039	(R)	Controller error: Dither RAM R/W error
100-3040	(R)	Controller error: Amp. RAM R/W error
100-3041	(R)	Controller error: Unexpected external int
100-3042	(R)	Controller error: Unexpected serial port int
100-3043	(R)	Controller error: Unexpected software timer int
100-3044	(R)	Controller error: Unexpected HSO int
100-3045	(R)	Controller error: Unexpected HSI DATA int
100-3046	(R)	Controller error: Unexpected ad int
100-3047	(R)	Controller error: Unexpected timer overflow int
100-3048	(R)	Controller error: Unexpected shftfull int
100-3049	(R)	Controller error: Program terminated
100-3050	(R)	Controller error: In main state machine
100-3051	(S)	The scanner's ID switch has been set to an invalid value. Please change switch setting.
		Troubleshooting sequence:
		1. Smart Card Reader board (CRx).
		2. Main controller board (SUx).
		3. Related cabling.
100-3052	(S)	SCB board error

Error Code	Corrective Action	Description
100-3053	(S)	CCB/CCE board error
100-3054	(S)	Unable to write to EEPROM/FLASH
		Troubleshooting sequence:
		1. Main controller board (SUx).
100-3055	(S)	Flash error: Vpp low
100-3056	(S)	Flash error: Unable to erase
100-3057	(S)	Flash error: Unable to program
100-3058	(S)	SCU board error
		Troubleshooting sequence:
		1. Main controller board (SUx).
100-3059	(S)	CBx board error
		Troubleshooting sequence:
		1. Camera board (CBx).
		2. Main controller board (SUx).
		3. Related cabling.
100-3060	(S)	PPU board error
100-3061	(S)	IMx board error
		Troubleshooting sequence:
		1. Interface board (IMx).
100-3062	(U)	Fan error
		Troubleshooting sequence:
		1. User interaction.
		2. Related mechanical parts.
		3. Lamp and Motor driver board (LMx)
100-3063	(U)	The scanner's replacable lamp cartridge is detached. Check that it is intact and correctly inserted.
		Troubleshooting sequence:
		1. User interaction.
		2. Related mechanical parts.
100-3064	(R)	LMx board error
		Troubleshooting sequence:
		1. Lamp and Motor driver board (LMx)
		2. Main controller board (SUx).
		3. Related cabling.
100-3065	(R)	Unable to communicate with MDx board.
		Troubleshooting sequence:
		1. ATAC controller board (MDx).
		2. Main controller board (SUx).
		3. Related cabling.
100-3066	(R)	Unable to use DSP
100-3067	(R)	DSP hardware error
100-3068	(S)	SKx, SKx board error
		Troubleshooting sequence:
		1. Operator Panel board (SKx).
100-3069	(U)	The scanner lamp cover is open. Please close it and retry the operation.
		Troubleshooting sequence:
		1. User interaction.

Error Code	Corrective Action	Description
100-4001	(U)	No supported scanner could be found. Check that the scanner is turned on and connected.
		Troubleshooting sequence:
		1. User interaction.
100-4002	(R)	Parameter list length error
		Troubleshooting sequence:
		1. PC (cable, PC hardware/software etc.)
		2. Firmware.
100-4003	(R)	Invalid command operation code
		Troubleshooting sequence:
		1. PC (cable, PC hardware/software etc.)
		2. Firmware.
100-4004	(R)	Logical unit not supported
		Troubleshooting sequence:
		1. PC (cable, PC hardware/software etc.)
100-4005	(R)	Invalid value in CDB
		Troubleshooting sequence:
		1. PC (cable, PC hardware/software etc.)
100-4006	(R)	An invalid field in the parameter list was set to a value
		Troubleshooting sequence:
		1. PC (cable, PC hardware/software etc.)
100-4007	(R)	An unsupported field in the parameter list was set to a value
		Troubleshooting sequence:
		1. PC (cable, PC hardware/software etc.)
100-4008	(R)	A field in the parameter list was set to an invalid value
		Troubleshooting sequence:
		1. PC (cable, PC hardware/software etc.)
100-4009	(R)	Invalid bits in identify message
		Troubleshooting sequence:
		1. Firmware.
100-5000	(R)	Command phase error
		Troubleshooting sequence:
		1. Firmware.
		2. PC (cable, PC hardware/software etc.)
		3. Interface board (IMx).
100-5001	(R)	Overlapped commands attempted
		Troubleshooting sequence:
		1. Firmware.
		2. PC (cable, PC hardware/software etc.)
		3. Interface board (IMx).
100-5002	(U)	The scanner operation was interrupted by a user.
		Troubleshooting sequence:
		1. User interaction.
100-8147	(U)	The scanner's ID switch has been set to an invalid value. Please change switch setting.
		Troubleshooting sequence:
		1. Smart Card Reader board (CRx).

Error Code	Corrective Action	Description
		2. Main controller board (SUx).
		3. Related cabling.
100-8149	(U)	The scanner's smart card is not a valid type for this scanner. Please replace it with a valid card.
		Troubleshooting sequence:
		1. User interaction.
100-8208	(U)	Keyboard check failed.
		Troubleshooting sequence:
		1. User interaction.
100-8220	(U)	The scanner's replacable lamp cartridge is detached. Check that it is intact and correctly inserted.
		Troubleshooting sequence:
		1. User interaction.
		2. Related mechanical parts.
100-8223	(U)	The scanner lamp cover is open. Please close it and retry the operation.
		Troubleshooting sequence:
		1. User interaction.
		2. Related mechanical parts.
100-20086	(S)	Unable to communicate with MDx board.
		Troubleshooting sequence:
		1. ATAC controller board (MDx).
		2. Main controller board (SUx).
		3. Related cabling.
100-20087	(U)	Unable to perform paper guide movement (ATAC). Please turn scanner off and on.
		Troubleshooting sequence:
		1. User interaction.
		2. ATAC controller board (MDx).
		3. Main controller board (SUx).
100-20219	(S)	Fan error.
		Troubleshooting sequence:
		1. Related mechanical parts.
		2. Lamp and Motor driver board (LMx)
100-20221	(S)	LMx, board error.
		Troubleshooting sequence:
		1. Lamp and Motor driver board (LMx)
		2. Main controller board (SUx).
		3. Related cabling.
100-30140	(U)	Correction of Camera A failed. Please clean the white background and the glass plate. Then run your maintenance software.
		Troubleshooting sequence:
		1. User interaction.
		2. Related mechanical parts.
		3. Camera board (CBx).
		4. Main controller board (SUx).
100-30141	(U)	Correction of Camera B failed. Please clean the white background and the glass plate. Then run your maintenance software.
		Troubleshooting sequence:

Error Code	Corrective Action	Description
		1. User interaction.
		2. Related mechanical parts.
		3. Camera board (CBx).
		4. Main controller board (SUx).
100-30142	(U)	Correction of Camera C failed. Please clean the white background and the glass plate. Then run your maintenance software.
		Troubleshooting sequence:
		1. User interaction.
		2. Related mechanical parts.
		3. Camera board (CBx).
		4. Main controller board (SUx).
100-30143	(U)	Correction of Camera D failed. Please clean the white background and the glass plate. Then run your maintenance software.
		Troubleshooting sequence:
		1. User interaction.
		2. Related mechanical parts.
		3. Camera board (CBx).
		4. Main controller board (SUx).
100-30222	(U)	The scanner lamp needs replacement.
		Troubleshooting sequence:
		1. User interaction.
		2. Related mechanical parts.
100-30240	(U)	Correction of Camera A failed. Please clean the white background and the glass plate. Then run your maintenance software.
		Troubleshooting sequence:
		1. User interaction.
		2. Related mechanical parts.
		3. Camera board (CBx).
		4. Main controller board (SUx).
100-30241	(U)	Correction of Camera B failed. Please clean the white background and the glass plate. Then run your maintenance software.
		Troubleshooting sequence:
		1. User interaction.
		2. Related mechanical parts.
		3. Camera board (CBx).
		4. Main controller board (SUx).
100-30242	(U)	Correction of Camera C failed. Please clean the white background and the glass plate. Then run your maintenance software.
		Troubleshooting sequence:
		1. User interaction.
		2. Related mechanical parts.
		3. Camera board (CBx).
		4. Main controller board (SUx).
100-30243	(U)	Correction of Camera D failed. Please clean the white background and the glass plate. Then run your maintenance software.
		Troubleshooting sequence:
		1. User interaction.
		2. Related mechanical parts.

Error Code	Corrective Action	Description
		3. Camera board (CBx).
		4. Main controller board (SUx).
100-32144	(U)	Stitching between Camera A and B failed. Please clean the white background and the glass plate. Then run your maintenance software.
		Troubleshooting sequence:
		1. User interaction.
		2. Related mechanical parts.
		3. Camera board (CBx).
		4. Main controller board (SUx).
100-32145	(U)	Stitching between Camera B and C failed. Please clean the white background and the glass plate. Then run your maintenance software.
		Troubleshooting sequence:
		1. User interaction.
		2. Related mechanical parts.
		3. Camera board (CBx).
		4. Main controller board (SUx).
100-32146	(U)	Stitching between Camera C and D failed. Please clean the white background and the glass plate. Then run your maintenance software.
		Troubleshooting sequence:
		1. User interaction.
		2. Related mechanical parts.
		3. Camera board (CBx).
		4. Main controller board (SUx).
100-32244	(U)	Stitching between Camera A and B failed. Please clean the white background and the glass plate. Then run your maintenance software.
		Troubleshooting sequence:
		1. User interaction.
		2. Related mechanical parts.
		3. Camera board (CBx).
		4. Main controller board (SUx).
100-32245	(U)	Stitching between Camera B and C failed. Please clean the white background and the glass plate. Then run your maintenance software.
		Troubleshooting sequence:
		1. User interaction.
		2. Related mechanical parts.
		3. Camera board (CBx).
		4. Main controller board (SUx).
100-32246	(U)	Stitching between Camera C and D failed. Please clean the white background and the glass plate. Then run your maintenance software.
		Troubleshooting sequence:
		1. User interaction.
		2. Related mechanical parts.
		3. Camera board (CBx).
		4. Main controller board (SUx).
100-40035	(S)	CBx, Camera A not found
		Troubleshooting sequence:
		1. Camera board (CBx).
		2. Main controller board (SUx).

Error Code	Corrective Action	Description
		3. Related cabling.
100-40036	(S)	CBx, Camera B not found
		Troubleshooting sequence:
		1. Camera board (CBx).
		2. Main controller board (SUx).
		3. Related cabling.
100-40037	(S)	CBx, Camera C not found
		Troubleshooting sequence:
		1. Camera board (CBx).
		2. Main controller board (SUx).
		3. Related cabling.
100-40038	(S)	CBx, Camera D not found
		Troubleshooting sequence:
		1. Camera board (CBx).
		2. Main controller board (SUx).
		3. Related cabling.
100-40039	(S)	CBx, Camera A AMP RAM error
		Troubleshooting sequence:
		1. Camera board (CBx).
		2. Main controller board (SUx).
		3. Related cabling.
100-40040	(S)	CBx, Camera B AMP RAM error
		Troubleshooting sequence:
		1. Camera board (CBx).
		2. Main controller board (SUx).
		3. Related cabling.
100-40041	(S)	CBx, Camera C AMP RAM error
		Troubleshooting sequence:
		1. Camera board (CBx).
		2. Main controller board (SUx).
		3. Related cabling.
100-40042	(S)	CBx, Camera D AMP RAM error
		Troubleshooting sequence:
		1. Camera board (CBx).
		2. Main controller board (SUx).
		3. Related cabling.
100-40043	(S)	CBx, Camera A EVEN LINE RAM error
		Troubleshooting sequence:
		1. Camera board (CBx).
		2. Main controller board (SUx).
		3. Related cabling.
100-40044	(S)	CBx, Camera B EVEN LINE RAM error
		Troubleshooting sequence:
		1. Camera board (CBx).
		2. Main controller board (SUx).
		3. Related cabling.
100-40045	(S)	CBx, Camera C EVEN LINE RAM error

Error Code	Corrective Action	Description
		Troubleshooting sequence:
		1. Camera board (CBx).
		2. Main controller board (SUx).
		3. Related cabling.
100-40046	(S)	CBx, Camera D EVEN LINE RAM error
		Troubleshooting sequence:
		1. Camera board (CBx).
		2. Main controller board (SUx).
		3. Related cabling.
100-40047	(S)	CBx, Camera A ODD LINE RAM error
		Troubleshooting sequence:
		1. Camera board (CBx).
		2. Main controller board (SUx).
		3. Related cabling.
100-40048	(S)	CBx, Camera B ODD LINE RAM error
		Troubleshooting sequence:
		1. Camera board (CBx).
		2. Main controller board (SUx).
		3. Related cabling.
100-40049	(S)	CBx, Camera C ODD LINE RAM error
		Troubleshooting sequence:
		1. Camera board (CBx).
		2. Main controller board (SUx).
		3. Related cabling.
100-40050	(S)	CBx, Camera D ODD LINE RAM error
		Troubleshooting sequence:
		1. Camera board (CBx).
		2. Main controller board (SUx).
		3. Related cabling.
100-40075	(S)	CBx, FPGA CB status error
		Troubleshooting sequence:
		1. Camera board (CBx).
		2. Main controller board (SUx).
		3. Related cabling.
100-40076	(S)	CBx, FPGA CB done error
		Troubleshooting sequence:
		1. Camera board (CBx).
		2. Main controller board (SUx).
		3. Related cabling.
100-40084	(S)	CBx, Camera cables misplaced
		Troubleshooting sequence:
		1. Camera board (CBx).
		2. Main controller board (SUx).
		3. Related cabling.
100-40134	(S)	Unable to basic calibrate
		Troubleshooting sequence:
		1. Switch Mode Power Supply (SMPS)

Error Code	Corrective Action	Description
		2. Camera board (CBx).
		3. Main controller board (SUx).
		4. Related cabling.
100-40135	(S)	Unable to calibrate analog offset
		Troubleshooting sequence:
		1. Switch Mode Power Supply (SMPS)
		2. Camera board (CBx).
		3. Main controller board (SUx).
		4. Related cabling.
100-40136	(S)	Unable to calibrate analog gain
		Troubleshooting sequence:
		1. Switch Mode Power Supply (SMPS)
		2. Camera board (CBx).
		3. Main controller board (SUx).
		4. Related cabling.
100-40137	(S)	Unable to calibrate pixel offset
		Troubleshooting sequence:
		1. Switch Mode Power Supply (SMPS)
		2. Camera board (CBx).
		3. Main controller board (SUx).
		4. Related cabling.
100-40138	(S)	Timed-out on calibrating analog part
		Troubleshooting sequence:
		1. Switch Mode Power Supply (SMPS)
		2. Camera board (CBx).
		3. Main controller board (SUx).
		4. Related cabling.
100-40139	(S)	An IT8 white patch was 0
		Troubleshooting sequence:
		1. Switch Mode Power Supply (SMPS)
		2. Camera board (CBx).
		3. Main controller board (SUx).
		4. Related cabling.
100-40170	(S)	Camera A, Unable to calibrate analog offset
		Troubleshooting sequence:
		1. Switch Mode Power Supply (SMPS)
		2. Camera board (CBx).
		3. Main controller board (SUx).
		4. Related cabling.
100-40171	(S)	Camera B, Unable to calibrate analog offset
		Troubleshooting sequence:
		1. Switch Mode Power Supply (SMPS)
		2. Camera board (CBx).
		3. Main controller board (SUx).
		4. Related cabling.
100-40172	(S)	Camera C, Unable to calibrate analog offset
		Troubleshooting sequence:

Error Code	Corrective Action	Description
		1. Switch Mode Power Supply (SMPS)
		2. Camera board (CBx).
		3. Main controller board (SUx).
		4. Related cabling.
100-40173	(S)	Camera D, Unable to calibrate analog offset
		Troubleshooting sequence:
		1. Switch Mode Power Supply (SMPS)
		2. Camera board (CBx).
		3. Main controller board (SUx).
		4. Related cabling.
100-40174	(S)	Camera A, Unable to calibrate analog gain
		Troubleshooting sequence:
		1. Switch Mode Power Supply (SMPS)
		2. Camera board (CBx).
		3. Main controller board (SUx).
		4. Related cabling.
100-40175	(S)	Camera B, Unable to calibrate analog gain
		Troubleshooting sequence:
		1. Switch Mode Power Supply (SMPS)
		2. Camera board (CBx).
		3. Main controller board (SUx).
		4. Related cabling.
100-40176	(S)	Camera C, Unable to calibrate analog gain
		Troubleshooting sequence:
		1. Switch Mode Power Supply (SMPS)
		2. Camera board (CBx).
		3. Main controller board (SUx).
		4. Related cabling.
100-40177	(S)	Camera D, Unable to calibrate analog gain
		Troubleshooting sequence:
		1. Switch Mode Power Supply (SMPS)
		2. Camera board (CBx).
		3. Main controller board (SUx).
		4. Related cabling.
100-40178	(S)	Camera A, Unable to calibrate pixel offset
		Troubleshooting sequence:
		1. Switch Mode Power Supply (SMPS)
		2. Camera board (CBx).
		3. Main controller board (SUx).
		4. Related cabling.
100-40179	(S)	Camera B, Unable to calibrate pixel offset
		Troubleshooting sequence:
		1. Switch Mode Power Supply (SMPS)
		2. Camera board (CBx).
		3. Main controller board (SUx).
		4. Related cabling.
100-40180	(S)	Camera C, Unable to calibrate pixel offset

Error Code	Corrective Action	Description
		Troubleshooting sequence:
		1. Switch Mode Power Supply (SMPS)
		2. Camera board (CBx).
		3. Main controller board (SUx).
		4. Related cabling.
100-40181	(S)	Camera D, Unable to calibrate pixel offset
		Troubleshooting sequence:
		1. Switch Mode Power Supply (SMPS)
		2. Camera board (CBx).
		3. Main controller board (SUx).
		4. Related cabling.
100-40182	(S)	Camera A, Timed-out, calibrating analog part
		Troubleshooting sequence:
		1. Switch Mode Power Supply (SMPS)
		2. Camera board (CBx).
		3. Main controller board (SUx).
		4. Related cabling.
100-40183	(S)	Camera B, Timed-out, calibrating analog part
		Troubleshooting sequence:
		1. Switch Mode Power Supply (SMPS)
		2. Camera board (CBx).
		3. Main controller board (SUx).
		4. Related cabling.
100-40184	(S)	Camera C, Timed-out, calibrating analog part
		Troubleshooting sequence:
		1. Switch Mode Power Supply (SMPS)
		2. Camera board (CBx).
		3. Main controller board (SUx).
		4. Related cabling.
100-40185	(S)	Camera D, Timed-out, calibrating analog part
		Troubleshooting sequence:
		1. Switch Mode Power Supply (SMPS)
		2. Camera board (CBx).
		3. Main controller board (SUx).
		4. Related cabling.
100-40186	(S)	Camera A, Unable to calibrate ext. DAC
		Troubleshooting sequence:
		1. Switch Mode Power Supply (SMPS)
		2. Camera board (CBx).
		3. Main controller board (SUx).
		4. Related cabling.
100-40187	(S)	Camera B, Unable to calibrate ext. DAC
		Troubleshooting sequence:
		1. Switch Mode Power Supply (SMPS)
		2. Camera board (CBx).
		3. Main controller board (SUx).
		4. Related cabling.

Error Code	Corrective Action	Description
100-40188	(S)	Camera C, Unable to calibrate ext. DAC
		Troubleshooting sequence:
		1. Switch Mode Power Supply (SMPS)
		2. Camera board (CBx).
		3. Main controller board (SUx).
		4. Related cabling.
100-40189	(S)	Camera D, Unable to calibrate ext. DAC
		Troubleshooting sequence:
		1. Switch Mode Power Supply (SMPS)
		2. Camera board (CBx).
		3. Main controller board (SUx).
		4. Related cabling.
100-50017	(S)	SUx, Register 1 error
		Troubleshooting sequence:
		1. Main controller board (SUx).
100-50018	(S)	SUx, Register 2 error
		Troubleshooting sequence:
		1. Main controller board (SUx).
100-50019	(S)	SUx, Register 3 error
		Troubleshooting sequence:
		1. Main controller board (SUx).
100-50020	(S)	SUx, Register 6 error
		Troubleshooting sequence:
		1. Main controller board (SUx).
100-50021	(S)	SUx, Register 8 error
		Troubleshooting sequence:
		1. Main controller board (SUx).
100-50022	(S)	SUx, FPGA01 register error
		Troubleshooting sequence:
		1. Main controller board (SUx).
100-50023	(S)	SUx, FPGA03 register error
		Troubleshooting sequence:
		1. Main controller board (SUx).
100-50024	(S)	SUx, FPGA04 register error
		Troubleshooting sequence:
		1. Main controller board (SUx).
100-50025	(S)	SUx, FPGA05 register error
		Troubleshooting sequence:
		1. Main controller board (SUx).
100-50026	(S)	SUx, FPGA06 register error
		Troubleshooting sequence:
		1. Main controller board (SUx).
100-50027	(S)	SUx, FPGA07 register error
		Troubleshooting sequence:
		1. Main controller board (SUx).
100-50028	(S)	SUx, FPGA08 register error
		Troubleshooting sequence:

Error Code	Corrective Action	Description
		1. Main controller board (SUx).
100-50051	(S)	SUx, DB 0 reset error
		Troubleshooting sequence:
		1. Main controller board (SUx).
100-50052	(S)	SUx, DB 0 count error
		Troubleshooting sequence:
		1. Main controller board (SUx).
100-50053	(S)	SUx, DB 0 data error
		Troubleshooting sequence:
		1. Main controller board (SUx).
100-50054	(S)	SUx, DB 1 reset error
		Troubleshooting sequence:
		1. Main controller board (SUx).
100-50055	(S)	SUx, DB 1 count error
		Troubleshooting sequence:
		1. Main controller board (SUx).
100-50056	(S)	SUx, DB 1 data error
		Troubleshooting sequence:
		1. Main controller board (SUx).
100-50057	(S)	SUx, CNTL RAM error
		Troubleshooting sequence:
		1. Main controller board (SUx).
100-50058	(S)	SUx, LIN RAM error
		Troubleshooting sequence:
		1. Main controller board (SUx).
100-50059	(S)	SUx, GAMMA RAM error
		Troubleshooting sequence:
		1. Main controller board (SUx).
100-50060	(S)	SUx, INDEX RAM error
		Troubleshooting sequence:
		1. Main controller board (SUx).
100-50061	(S)	SUx, LUT ATBS error
		Troubleshooting sequence:
		1. Main controller board (SUx).
100-50062	(S)	SUx, LUT A error
		Troubleshooting sequence:
		1. Main controller board (SUx).
100-50063	(S)	SUx, LUT B error
		Troubleshooting sequence:
		1. Main controller board (SUx).
100-50064	(S)	SUx, LUT C error
		Troubleshooting sequence:
		1. Main controller board (SUx).
100-50065	(S)	SUx, Color space converter data error
		Troubleshooting sequence:
		1. Main controller board (SUx).
100-50066	(S)	SUx, Color space converter coefficient error

Error Code	Corrective Action	Description
		Troubleshooting sequence:
		1. Main controller board (SUx).
100-50067	(S)	SUx, Position counter reset error
		Troubleshooting sequence:
		1. Main controller board (SUx).
100-50068	(S)	SUx, Position counter count error
		Troubleshooting sequence:
		1. Main controller board (SUx).
100-50069	(S)	SUx, Data path error
		Troubleshooting sequence:
		1. Main controller board (SUx).
100-50070	(S)	SUx, Data path length error
		Troubleshooting sequence:
		1. Main controller board (SUx).
100-50071	(S)	SUx, FPGA 8k status error
		Troubleshooting sequence:
		1. Main controller board (SUx).
100-50072	(S)	SUx, FPGA 8k done error
		Troubleshooting sequence:
		1. Main controller board (SUx).
100-50073	(S)	SUx, FPGA 10k status error
		Troubleshooting sequence:
		1. Main controller board (SUx).
100-50074	(S)	SUx, FPGA 10k done error
		Troubleshooting sequence:
		1. Main controller board (SUx).
100-50077	(S)	SUx, FPGA 6k status error
		Troubleshooting sequence:
		1. Main controller board (SUx).
100-50078	(S)	SUx, FPGA 6k done error
		Troubleshooting sequence:
		1. Main controller board (SUx).
100-50079	(S)	SUx, FPGA 20k status error
		Troubleshooting sequence:
		1. Main controller board (SUx).
100-50080	(S)	SUx, FPGA 20k done error
		Troubleshooting sequence:
		1. Main controller board (SUx).
100-50081	(S)	SUx, FPGA03 function error
		Troubleshooting sequence:
		1. Main controller board (SUx).
100-50088	(S)	Hardware identification error.
		Troubleshooting sequence:
		1. Main controller board (SUx).
100-50089	(U)	Invalid firmware for this type of scanner. Please download new firmware
		Troubleshooting sequence:
		1. User interaction.

Error Code	Corrective Action	Description
100-50090	(S)	SUx, Sector in writeable area of FLASH locked
		Troubleshooting sequence:
		1. Main controller board (SUx).
100-50091	(S)	SUx, Parameter block erasure failed
		Troubleshooting sequence:
		1. Main controller board (SUx).
100-50092	(S)	SUx, Parameter block write failed
		Troubleshooting sequence:
		1. Main controller board (SUx).
100-50093	(S)	SUx, Profile block erasure failed
		Troubleshooting sequence:
		1. Main controller board (SUx).
100-50094	(S)	SUx, Profile block write failed
		Troubleshooting sequence:
		1. Main controller board (SUx).
100-50095	(S)	SUx, Flash block erasure failed
		Troubleshooting sequence:
		1. Main controller board (SUx).
100-50096	(S)	SUx, Flash block write failed
		Troubleshooting sequence:
		1. Main controller board (SUx).
100-50099	(S)	SUx, Unknown flash device type
		Troubleshooting sequence:
		1. Main controller board (SUx).
100-50100	(R)	pad task creation failed
		Troubleshooting sequence:
		1. Firmware.
100-50101	(R)	pcd task creation failed
		Troubleshooting sequence:
		1. Firmware.
100-50102	(R)	pbl task creation failed
		Troubleshooting sequence:
		1. Firmware.
100-50103	(R)	err task creation failed
		Troubleshooting sequence:
		1. Firmware.
100-50104	(R)	pio task creation failed
		Troubleshooting sequence:
		1. Firmware.
100-50105	(R)	pop task creation failed
		Troubleshooting sequence:
		1. Firmware.
100-50106	(R)	psn task creation failed
		Troubleshooting sequence:
		1. Firmware.
100-50107	(R)	psc task creation failed
		Troubleshooting sequence:

Error Code	Corrective Action	Description
		1. Firmware.
100-50108	(R)	psi task creation failed
		Troubleshooting sequence:
		1. Firmware.
100-50109	(R)	psp task creation failed
		Troubleshooting sequence:
		1. Firmware.
100-50110	(R)	pts task creation failed
		Troubleshooting sequence:
		1. Firmware.
100-50111	(R)	pto task creation failed
		Troubleshooting sequence:
		1. Firmware.
100-50112	(R)	mbPad creation failed
		Troubleshooting sequence:
		1. Firmware.
100-50113	(R)	mbPbl creation failed
		Troubleshooting sequence:
		1. Firmware.
100-50114	(R)	mbPcd creation failed
		Troubleshooting sequence:
		1. Firmware.
100-50115	(R)	mbPio creation failed
		Troubleshooting sequence:
		1. Firmware.
100-50116	(R)	mbPsi creation failed
		Troubleshooting sequence:
		1. Firmware.
100-50117	(R)	mbPsp creation failed
		Troubleshooting sequence:
		1. Firmware.
100-50118	(R)	mbPts creation failed
		Troubleshooting sequence:
		1. Firmware.
100-50119	(R)	mbPio pending
		Troubleshooting sequence:
		1. Firmware.
100-50120	(R)	hmm out of memory
		Troubleshooting sequence:
		1. Firmware.
100-50121	(R)	hmm un-allocated memory block
		Troubleshooting sequence:
		1. Firmware.
100-50122	(R)	pop request failed, position unknown
		Troubleshooting sequence:
		1. PC (cable, PC hardware/software etc.)
		2. Firmware.

Error Code	Corrective Action	Description
100-50123	(R)	pop request failed, invalid command
		Troubleshooting sequence:
		1. PC (cable, PC hardware/software etc.)
		2. Firmware.
100-50124	(R)	pio event
		Troubleshooting sequence:
		1. Firmware.
		2. Related mechanical parts.
100-50125	(R)	psi event
		Troubleshooting sequence:
		1. PC (cable, PC hardware/software etc.)
		2. Firmware.
		3. Interface board (IMx).
100-50126	(R)	pcd event
		Troubleshooting sequence:
		1. Firmware.
100-50127	(R)	psc event
		Troubleshooting sequence:
		1. Firmware.
100-50128	(R)	psi message event
		Troubleshooting sequence:
		1. PC (cable, PC hardware/software etc.)
		2. Firmware.
		3. Interface board (IMx).
100-50130	(R)	semPsp posted more than once
		Troubleshooting sequence:
		1. Firmware.
100-50131	(R)	psp received unknown mail
		Troubleshooting sequence:
		1. Firmware.
100-50132	(R)	mrsErrorTbl missing entry
		Troubleshooting sequence:
		1. Firmware.
100-50133	(R)	unknown reboot command
		Troubleshooting sequence:
		1. Firmware.
100-50190	(R)	pbl received invalid mail
		Troubleshooting sequence:
		1. Firmware.
100-50191	(R)	mbPss creation failed
		Troubleshooting sequence:
		1. Firmware.
100-50192	(R)	pss task creation failed
		Troubleshooting sequence:
		1. Firmware.
100-50193	(R)	mbPss pending
		Troubleshooting sequence:

Error Code	Corrective Action	Description
		1. Firmware.
100-50194	(R)	pss event
		Troubleshooting sequence:
		1. Firmware.
100-50195	(R)	stitch write failed
		Troubleshooting sequence:
		1. Main controller board (SUx).
100-50196	(R)	pmb validation failed
		Troubleshooting sequence:
		1. Main controller board (SUx).
100-50197	(R)	pointer out of range
		Troubleshooting sequence:
		1. Firmware.
100-50198	(R)	Incorrect camera board. Please check all camera board types.
		Troubleshooting sequence:
		1. Firmware.
100-50199	(S)	Incorrect SUx/CBx combination. Please validate the combination for this scanner.
		Troubleshooting sequence:
		1. Camera board (CBx).
		2. Main controller board (SUx).
		3. Related cabling.
		4. Firmware.
100-50200	(R)	invalid timeout task
		Troubleshooting sequence:
		1. Firmware.
100-50201	(R)	invalid data length
		Troubleshooting sequence:
		1. PC (cable, PC hardware/software etc.)
		2. Firmware.
100-50202	(R)	semPsp already owned by this SCSI unit
		Troubleshooting sequence:
		1. Firmware.
100-50203	(R)	semPsp not released
		Troubleshooting sequence:
		1. Firmware.
100-50204	(R)	new failed, out of memory
		Troubleshooting sequence:
		1. Firmware.
100-50206	(R)	Light profile flash space overrun
		Troubleshooting sequence:
		1. Firmware.
100-50207	(R)	pkb task creation failed
		Troubleshooting sequence:
		1. Firmware.
100-50209	(R)	ppw task creation failed
		Troubleshooting sequence:
		1. Firmware.

Error Code	Corrective Action	Description
100-50210	(R)	mbPpw creation failed
		Troubleshooting sequence:
		1. Firmware.
100-50211	(R)	pus task creation failed
		Troubleshooting sequence:
		1. Firmware.
100-50212	(R)	mbPus creation failed
		Troubleshooting sequence:
		1. User interaction.
		2. PC (cable, PC hardware/software etc.)
		3. Firmware.
		4. Interface board (IMx).
100-50213	(R)	pus event
		Troubleshooting sequence:
		1. Firmware.
100-50214	(R)	psp task delete failed
		Troubleshooting sequence:
		1. Firmware.
100-50215	(R)	pfi task creation failed
		Troubleshooting sequence:
		1. Firmware.
100-50216	(R)	mbPfi creation failed
		Troubleshooting sequence:
		1. User interaction.
		2. PC (cable, PC hardware/software etc.)
		3. Firmware.
		4. Interface board (IMx).
100-50217	(R)	pfi event
		Troubleshooting sequence:
		1. User interaction.
		2. Related mechanical parts.
		3. Camera board (CBx).
		4. Main controller board (SUx).
100-50300	(R)	Unable to set scanner model
		Troubleshooting sequence:
		1. Firmware.
100-50301	(R)	Unable to set lost pixels
		Troubleshooting sequence:
		1. Firmware.
100-50302	(U)	Invalid FRAM contents. Try downloading new firmware.
		Troubleshooting sequence:
		1. User interaction.
100-50303	(U)	Scanner has no serial number.
		Troubleshooting sequence:
		1. User interaction.
100-50500	(S)	SUx, 386 CPU error
		Troubleshooting sequence:

Error Code	Corrective Action	Description
		1. Main controller board (SUx).
100-50501	(S)	SUx, CPU FIFO error
		Troubleshooting sequence:
		1. Main controller board (SUx).
100-50502	(S)	SUx, Ethernet PHY chip error
		Troubleshooting sequence:
		1. Main controller board (SUx).
100-50503	(S)	SUx, USB2 chip error
		Troubleshooting sequence:
		1. Main controller board (SUx).
100-50504	(S)	SKx, SKx board error
		Troubleshooting sequence:
		1. Operator Panel board (SKx).
100-50505	(S)	SUx. FRAM Error. Try downloading new firmware.
		Troubleshooting sequence:
		1. User interaction.
		2. Main controller board (SUx).
100-50506	(S)	SUx, DoubleBuffer DMA Error
		Troubleshooting sequence:
		1. Main controller board (SUx).
100-50507	(S)	SUx, Main FPGA load failed
		Troubleshooting sequence:
		1. Main controller board (SUx).
100-50508	(S)	SUx, Camera FPGA load failed
		Troubleshooting sequence:
		1. Main controller board (SUx).
100-50509	(S)	SUx, Main FPGA register error
		Troubleshooting sequence:
		1. Main controller board (SUx).
100-50510	(S)	SUx, Invalid Ethernet MAC address
		Troubleshooting sequence:
		1. Main controller board (SUx).
100-50511	(S)	SUx, Ethernet PHY connector error or missing loopback plug
		Troubleshooting sequence:
		1. Main controller board (SUx).
100-50512	(S)	SUx, Ethernet MAC-PHY interface error
		Troubleshooting sequence:
		1. Main controller board (SUx).
100-60029	(S)	IMx, SCSI 0 reset error
		Troubleshooting sequence:
		1. Interface board (IMx).
		2. Main controller board (SUx).
100-60030	(S)	IMx, SCSI 0 register error
		Troubleshooting sequence:
		1. Interface board (IMx).
		2. Main controller board (SUx).
100-60031	(S)	IMx, SCSI 0 FIFO error

Error Code	Corrective Action	Description
		Troubleshooting sequence:
		1. Interface board (IMx).
		2. Main controller board (SUx).
100-60032	(S)	IMx, SCSI 1 reset error
		Troubleshooting sequence:
		1. Interface board (IMx).
		2. Main controller board (SUx).
100-60033	(S)	IMx, SCSI 1 register error
		Troubleshooting sequence:
		1. Interface board (IMx).
		2. Main controller board (SUx).
100-60034	(S)	IMx, SCSI 1 FIFO error
		Troubleshooting sequence:
		1. Interface board (IMx).
		2. Main controller board (SUx).
100-60082	(S)	IMx, USB chip error
		Troubleshooting sequence:
		1. Interface board (IMx).
		2. Main controller board (SUx).
100-60083	(S)	IMx, wrong board version installed
		Troubleshooting sequence:
		1. Interface board (IMx).
		2. Main controller board (SUx).
100-60085	(S)	IMx, 1394 chip error
		Troubleshooting sequence:
		1. Interface board (IMx).
		2. Main controller board (SUx).